



Fire Alarm Control Panel
NFS2-640/E
Programming Manual

Document 52742
7/17/14

Rev:

L2

P/N 52742:L2

ECN 13-838

Fire Alarm & Emergency Communication System Limitations

While a life safety system may lower insurance rates, it is not a substitute for life and property insurance!

An automatic fire alarm system—typically made up of smoke detectors, heat detectors, manual pull stations, audible warning devices, and a fire alarm control panel (FACP) with remote notification capability—can provide early warning of a developing fire. Such a system, however, does not assure protection against property damage or loss of life resulting from a fire.

An emergency communication system—typically made up of an automatic fire alarm system (as described above) and a life safety communication system that may include an autonomous control unit (ACU), local operating console (LOC), voice communication, and other various interoperable communication methods—can broadcast a mass notification message. Such a system, however, does not assure protection against property damage or loss of life resulting from a fire or life safety event.

The Manufacturer recommends that smoke and/or heat detectors be located throughout a protected premises following the recommendations of the current edition of the National Fire Protection Association Standard 72 (NFPA 72), manufacturer's recommendations, State and local codes, and the recommendations contained in the Guide for Proper Use of System Smoke Detectors, which is made available at no charge to all installing dealers. This document can be found at <http://www.systemsensor.com/appguides/>. A study by the Federal Emergency Management Agency (an agency of the United States government) indicated that smoke detectors may not go off in as many as 35% of all fires. While fire alarm systems are designed to provide early warning against fire, they do not guarantee warning or protection against fire. A fire alarm system may not provide timely or adequate warning, or simply may not function, for a variety of reasons:

Smoke detectors may not sense fire where smoke cannot reach the detectors such as in chimneys, in or behind walls, on roofs, or on the other side of closed doors. Smoke detectors also may not sense a fire on another level or floor of a building. A second-floor detector, for example, may not sense a first-floor or basement fire.

Particles of combustion or "smoke" from a developing fire may not reach the sensing chambers of smoke detectors because:

- Barriers such as closed or partially closed doors, walls, chimneys, even wet or humid areas may inhibit particle or smoke flow.
- Smoke particles may become "cold," stratify, and not reach the ceiling or upper walls where detectors are located.
- Smoke particles may be blown away from detectors by air outlets, such as air conditioning vents.
- Smoke particles may be drawn into air returns before reaching the detector.

The amount of "smoke" present may be insufficient to alarm smoke detectors. Smoke detectors are designed to alarm at various levels of smoke density. If such density levels are not created by a developing fire at the location of detectors, the detectors will not go into alarm.

Smoke detectors, even when working properly, have sensing limitations. Detectors that have photoelectronic sensing chambers tend to detect smoldering fires better than flaming fires, which have little visible smoke. Detectors that have ionizing-type sensing chambers tend to detect fast-flaming fires better than smoldering fires. Because fires develop in different ways and are often unpredictable in their growth, neither type of detector is necessarily best and a given type of detector may not provide adequate warning of a fire.

Smoke detectors cannot be expected to provide adequate warning of fires caused by arson, children playing with matches (especially in bedrooms), smoking in bed, and violent explosions

(caused by escaping gas, improper storage of flammable materials, etc.).

Heat detectors do not sense particles of combustion and alarm only when heat on their sensors increases at a predetermined rate or reaches a predetermined level. Rate-of-rise heat detectors may be subject to reduced sensitivity over time. For this reason, the rate-of-rise feature of each detector should be tested at least once per year by a qualified fire protection specialist. Heat detectors are designed to protect property, not life.

IMPORTANT! Smoke detectors must be installed in the same room as the control panel and in rooms used by the system for the connection of alarm transmission wiring, communications, signaling, and/or power. If detectors are not so located, a developing fire may damage the alarm system, compromising its ability to report a fire.

Audible warning devices such as bells, horns, strobes, speakers and displays may not alert people if these devices are located on the other side of closed or partly open doors or are located on another floor of a building. Any warning device may fail to alert people with a disability or those who have recently consumed drugs, alcohol, or medication. Please note that:

- An emergency communication system may take priority over a fire alarm system in the event of a life safety emergency.
- Voice messaging systems must be designed to meet intelligibility requirements as defined by NFPA, local codes, and Authorities Having Jurisdiction (AHJ).
- Language and instructional requirements must be clearly disseminated on any local displays.
- Strobes can, under certain circumstances, cause seizures in people with conditions such as epilepsy.
- Studies have shown that certain people, even when they hear a fire alarm signal, do not respond to or comprehend the meaning of the signal. Audible devices, such as horns and bells, can have different tonal patterns and frequencies. It is the property owner's responsibility to conduct fire drills and other training exercises to make people aware of fire alarm signals and instruct them on the proper reaction to alarm signals.
- In rare instances, the sounding of a warning device can cause temporary or permanent hearing loss.

A life safety system will not operate without any electrical power. If AC power fails, the system will operate from standby batteries only for a specified time and only if the batteries have been properly maintained and replaced regularly.

Equipment used in the system may not be technically compatible with the control panel. It is essential to use only equipment listed for service with your control panel.

Telephone lines needed to transmit alarm signals from a premises to a central monitoring station may be out of service or temporarily disabled. For added protection against telephone line failure, backup radio transmission systems are recommended.

The most common cause of life safety system malfunction is inadequate maintenance. To keep the entire life safety system in excellent working order, ongoing maintenance is required per the manufacturer's recommendations, and UL and NFPA standards. At a minimum, the requirements of NFPA 72 shall be followed. Environments with large amounts of dust, dirt, or high air velocity require more frequent maintenance. A maintenance agreement should be arranged through the local manufacturer's representative. Maintenance should be scheduled monthly or as required by National and/or local fire codes and should be performed by authorized professional life safety system installers only. Adequate written records of all inspections should be kept.

Limit-D-1-2013

Installation Precautions

Adherence to the following will aid in problem-free installation with long-term reliability:

WARNING - Several different sources of power can be connected to the fire alarm control panel. Disconnect all sources of power before servicing. Control unit and associated equipment may be damaged by removing and/or inserting cards, modules, or interconnecting cables while the unit is energized. Do not attempt to install, service, or operate this unit until manuals are read and understood.

CAUTION - System Re-acceptance Test after Software Changes: To ensure proper system operation, this product must be tested in accordance with NFPA 72 after any programming operation or change in site-specific software. Re-acceptance testing is required after any change, addition or deletion of system components, or after any modification, repair or adjustment to system hardware or wiring. All components, circuits, system operations, or software functions known to be affected by a change must be 100% tested. In addition, to ensure that other operations are not inadvertently affected, at least 10% of initiating devices that are not directly affected by the change, up to a maximum of 50 devices, must also be tested and proper system operation verified.

This system meets NFPA requirements for operation at 0-49° C/32-120° F and at a relative humidity 93% ± 2% RH (non-condensing) at 32°C ± 2°C (90°F ± 3°F). However, the useful life of the system's standby batteries and the electronic components may be adversely affected by extreme temperature ranges and humidity. Therefore, it is recommended that this system and its peripherals be installed in an environment with a normal room temperature of 15-27° C/60-80° F.

Verify that wire sizes are adequate for all initiating and indicating device loops. Most devices cannot tolerate more than a 10% I.R. drop from the specified device voltage.

Like all solid state electronic devices, this system may operate erratically or can be damaged when subjected to lightning induced transients. Although no system is completely immune from lightning transients and interference, proper grounding will reduce susceptibility. Overhead or outside aerial wiring is not recommended, due to an increased susceptibility to nearby lightning strikes. Consult with the Technical Services Department if any problems are anticipated or encountered.

Disconnect AC power and batteries prior to removing or inserting circuit boards. Failure to do so can damage circuits.

Remove all electronic assemblies prior to any drilling, filing, reaming, or punching of the enclosure. When possible, make all cable entries from the sides or rear. Before making modifications, verify that they will not interfere with battery, transformer, or printed circuit board location.

Do not tighten screw terminals more than 9 in-lbs. Over-tightening may damage threads, resulting in reduced terminal contact pressure and difficulty with screw terminal removal.

This system contains static-sensitive components. Always ground yourself with a proper wrist strap before handling any circuits so that static charges are removed from the body. Use static suppressive packaging to protect electronic assemblies removed from the unit.

Follow the instructions in the installation, operating, and programming manuals. These instructions must be followed to avoid damage to the control panel and associated equipment. FACP operation and reliability depend upon proper installation.

Precau-D1-9-2005

FCC Warning

WARNING: This equipment generates, uses, and can radiate radio frequency energy and if not installed and used in accordance with the instruction manual may cause interference to radio communications. It has been tested and found to comply with the limits for class A computing devices pursuant to Subpart B of Part 15 of FCC Rules, which is designed to provide reasonable protection against such interference when devices are operated in a commercial environment. Operation of this equipment in a residential area is likely to cause interference, in which case the user will be required to correct the interference at his or her own expense.

Canadian Requirements

This digital apparatus does not exceed the Class A limits for radiation noise emissions from digital apparatus set out in the Radio Interference Regulations of the Canadian Department of Communications.

Le présent appareil numérique n'émet pas de bruits radioélectriques dépassant les limites applicables aux appareils numériques de la classe A prescrites dans le Règlement sur le brouillage radioélectrique édicté par le ministère des Communications du Canada.

HARSH™, NIS™, NOTI•FIRE•NET™, eVance™, and SWIFT™ are all trademarks; and Acclimate® Plus, FAAST®, FlashScan®, NION®, NOTIFIER®, ONYX®, ONYXWorks®, UniNet®, VeriFire®, and VIEW® are all registered trademarks of Honeywell International Inc. Echelon® is a registered trademark and LonWorks™ is a trademark of Echelon Corporation. ARCNET® is a registered trademark of Datapoint Corporation. Microsoft® and Windows® are registered trademarks of the Microsoft Corporation.

©2014 by Honeywell International Inc. All rights reserved. Unauthorized use of this document is strictly prohibited.

Software Downloads

In order to supply the latest features and functionality in fire alarm and life safety technology to our customers, we make frequent upgrades to the embedded software in our products. To ensure that you are installing and programming the latest features, we strongly recommend that you download the most current version of software for each product prior to commissioning any system. Contact Technical Support with any questions about software and the appropriate version for a specific application.

Documentation Feedback

Your feedback helps us keep our documentation up-to-date and accurate. If you have any comments or suggestions about our online Help or printed manuals, you can email us.

Please include the following information:

- Product name and version number (if applicable)
- Printed manual or online Help
- Topic Title (for online Help)
- Page number (for printed manual)
- Brief description of content you think should be improved or corrected
- Your suggestion for how to correct/improve documentation

Send email messages to:

FireSystems.TechPubs@honeywell.com

Please note this email address is for documentation feedback only. If you have any technical issues, please contact Technical Services.

Table of Contents

Section 1: General Information.....	7
1.1: UL 864 Compliance.....	7
1.1.1: Products Subject to AHJ Approval.....	7
1.1.2: Programming Features Subject to AHJ Approval	7
1.2: About This Manual	8
1.2.1: Cautions, Warning, and Notes.....	8
1.2.2: Typographic Conventions.....	8
1.2.3: Supplemental Information	9
1.2.4: Shortcuts to Operating Functions	10
1.3: Introduction to the Control Panel	10
1.4: Features.....	11
1.5: How to Enter a Password.....	11
Section 2: Programming	13
2.1: Overview.....	13
2.2: How to Enter Programming.....	14
2.3: Basic Program.....	14
2.3.1: Clear Memory (0=CLR).....	15
2.3.2: Autoprogram the Control Panel (1=AUTO).....	15
2.3.3: Modify or Delete a Point (2=POINT).....	19
2.3.4: Change a Password (3=PASSWD).....	25
2.3.5: Create a System Message (4=MESSAGE)	26
2.3.6: Create a Custom Zone Label (5=ZONE).....	27
2.3.7: Program Special Zones (6=SPL FUNCT)	27
2.3.8: Change Global System Functions (7=SYSTEM)	31
2.3.9: How to Check the Program for Errors (8=CHECK PRG).....	47
2.4: The Network Program	47
2.5: The Utility Program.....	48
2.6: FlashScan Poll	49
2.7: Setting the Baud Rate of Serial Ports	50
2.7.1: Printer Serial Port	50
2.7.2: CRT Serial Port	51
Section 3: Status Change.....	52
3.1: Overview.....	52
3.2: How to Enter Status Change.....	52
3.3: Disable or Enable a Point	53
3.4: Changing Detector Sensitivity.....	54
3.5: Clearing Alarm Verification Counters	55
3.6: Clearing the History Buffer	55
3.7: Setting the System Time and Date.....	55
3.8: Walk Test	56
3.8.1: Basic Walk Test.....	57
3.8.2: Advanced Walk Test	58
3.8.3: Walk Test Activation Indications	58
3.8.4: Viewing Walk Test Results	59
A.1: Overview.....	60
A.1.1: Description of Releasing Zones.....	60
A.1.2: NFPA Releasing Applications.....	61
A.2: How to Program a Releasing Zone	61
A.2.1: Programming a Delay Timer	61
A.2.2: Abort Switches.....	62
A.2.3: Using Cross Zones.....	70
A.2.4: Programming a Soak Timer.....	72
A.2.5: Using Type Codes for Releasing Zones	73

A.3: Initiating Devices	91
A.4: Warning Sounders	91
A.5: Auxiliary Control Functions	91
A.6: ACS Annunciation	91
B.1: Presignal and Positive Alarm Sequence (PAS)	92
B.1.1: What is Presignal and PAS?.....	92
B.1.2: Selecting Presignal and PAS Outputs	93
B.2: Time Control Zones.....	93
B.3: Coding Functions for NACS	93
C.1: Overview	95
C.2: Features	95
C.2.1: Drift Compensation and Smoothing	95
C.2.2: Maintenance Warnings – Three Levels	96
C.2.3: Self-Optimizing Pre-Alarm	97
C.2.4: Detector Sensitivity	97
C.2.5: Cooperative Multi-Detector Sensing	98
C.3: Pre-Alarm	99
C.3.1: Definition	99
C.3.2: Alert Level	99
C.3.3: Action Level.....	100
C.3.4: How to Select a Pre-Alarm Level	100
C.4: Detector Sensitivity Settings	101
C.4.1: How to Select Pre-Alarm and Alarm Sensitivity	101
C.4.2: How to Test Detectors Set Below 0.50% Obscuration per Foot.....	102
C.5: Detector Maintenance Features	103
C.5.1: Overview	103
C.5.2: How to Access Detector Maintenance Information	103
C.5.3: View Detector Maintenance for a Detector	103
C.5.4: Print a Detector Maintenance Report.....	104
C.5.5: Interpreting a Detector Status Display or Maintenance Report	104
D.1: Description	106
D.2: Input and Outputs.....	106
D.3: Equations.....	106
D.4: Equation Entry	107
D.4.1: Logic Functions	107
D.4.2: Equation Syntax Example.....	108
D.4.3: Evaluating an Equation	108
D.4.4: Argument Entries.....	108
D.4.5: Time Delay Functions.....	109
D.5: CBE Example.....	109
E.1: Overview	110
E.2: System Testing and Detector Initialization.....	110
E.3: How to Replace a Detector.....	110
E.4: How to Manually Initialize a Detector	111
F.1: What are Type Codes?	112
F.2: How to Select a Type Code.....	112
F.3: In this Appendix.....	112
F.4: Type Codes for Input Devices	112
F.4.1: Overview	112
F.4.2: Type Codes for Intelligent Detectors	112
F.4.3: Type Codes for Monitor Modules	114
F.5: Type Codes for Output Devices	115
F.5.1: Overview	115
F.5.2: Type Codes for Control Modules	115
F.5.3: NAC Type Codes	116
Index	121

Section 1: General Information

1.1 UL 864 Compliance

1.1.1 Products Subject to AHJ Approval

This product has been certified to comply with the requirements in the Standard for Control Units and Accessories for Fire Alarm Systems, UL 864 9th Edition.

A complete listing identifying which products have or have not received UL 864 9th Edition certification is located in the installation manual of this fire alarm system. Those products which have not received UL 864 9th Edition certification may only be used in retrofit applications. Operation of the NFS2-640/E with products not tested for UL 864 9th Edition has not been evaluated and may not comply with NFPA 72 and /or UL 864. These applications will require the approval of the local Authority Having Jurisdiction (AHJ).

1.1.2 Programming Features Subject to AHJ Approval

This product incorporates field-programmable software. The features and/or options listed below must be approved by the local AHJ.

Table 1.1 Programming Settings

This product incorporates field-programmable software. In order for the product to comply with the requirements in the Standard for Control Units and Accessories for Fire Alarm Systems, UL 864, certain programming features or options must be limited to specific values or not used at all as indicated below.			
Program Feature or Option	Permitted in UL 864? (Y/N)	Possible Settings	Settings Permitted in UL 864
IP downloads over a local area network (LAN) or the internet (WAN - Wide Area Network)	No	Yes No Timed	No
Releasing: Abort Switch	Yes	NYC AHJ ULI IRI	ULI IRI
Detector Programming: Supervisory Type Codes	Yes	SUP L(DUCTI) SUP T(DUCTI) SUP T(DUCTP) SUP L(DUCTP) SUP L(ION) SUP T(ION) SUP L(PHOTO) SUP T(PHOTO) SUP L(LASER) SUP T(LASER) PHOTO/CO (P SUP)	SUP L(DUCTI) SUP T(DUCTI) SUP L(DUCTP) SUP T(DUCTP)
ALA.SCROLL (Scroll Display)	No	Y N	N
TBL.REMIND	Yes	*, 1, 2, 3, 4, 5	2
REGION	No	0 (No special setting) 1 (China)	0 (No special setting)

1.2 About This Manual

1.2.1 Cautions, Warning, and Notes

The following graphics appear in the manual to indicate a caution or a warning.



CAUTION:

Information about procedures that could cause programming errors, runtime errors, or equipment damage.



WARNING:

Information about procedures that could cause irreversible damage to the control panel, irreversible loss of programming data or personal injury.



NOTE: Information that highlights an important part of the preceding or subsequent text or illustration.

1.2.2 Typographic Conventions

This manual uses the following conventions as listed below:

Table 1.2 Typographic Conventions in this Manual

When you see	Specifies	Example
text in small caps	the text as it appears in the LCD display or on the control panel	MARCH TIME is a selection that appears in the LCD display; or Press the ENTER key
text in quotes	a reference to a section or an LCD menu screen	“Status Change” specifies the Status Change section or menu screen
bold text	In body text, a number or character that you enter	Press 1 ; means to press the number “1” on the keypad
italic text	a specific document	<i>NFS2-640 Installation Manual</i>
a graphic of the key	In a graphic, a key as it appears on the control panel	Press  means to press the Escape key



NOTE: The term NFS2-640 is used in this manual to refer to the NFS2-640 and NFS2-640E unless otherwise noted.

1.2.3 Supplemental Information

The table below provides a list of documents referenced in this manual, as well as documents for selected other compatible devices. The document series chart (DOC-NOT) provides the current document revision. A copy of this document is included in every shipment.

Compatible Conventional Devices (Non-addressable)	Document Number
Device Compatibility Document	15378
Fire Alarm Control Panel (FACP) and Main Power Supply Installation	Document Number
NFS2-640/E Installation, Operations, and Programming Manuals	52741, 52742, 52743
SLC Wiring Manual	51253
Note: For individual SLC Devices, refer to the <i>SLC Wiring Manual</i>	
Off-line Programming Utility	Document Number
VeriFire® Tools CD help file	VERIFIRE-TCD
Veri•Fire Medium Systems Help File	VERIFIRE-CD
Cabinets & Chassis	Document Number
CAB-3/CAB-4 Series Cabinet Installation Document	15330
Battery/Peripherals Enclosure Installation Document	50295
Power Supplies, Auxiliary Power Supplies & Battery Chargers	Document Number
ACPS-610 Addressable Power Supply Manual	53018
ACPS-2406 Installation Manual	51304
APS-6R Instruction Manual	50702
APS2-6R Instruction Manual	53232
CHG-120 Battery Charger Manual	50641
FCPS-24 Field Charger/Power Supply Manual	50059
FCPS-24S Field Charger/Power Supply Manual (Sync)	51977
Networking	Document Number
Noti•Fire•Net Manual, Network Version 4.0 & Higher	51584
High-Speed Noti•Fire•Net Manual	54013
HS-NCM Installation Document	54014
NCM-W/F Installation Document	51533
NCS Network Control Station Manual, Network Version 4.0 & Higher	51658
NCA-2 Network Control Annunciator Manual	52482
ONYXWorks™ Workstation Manuals	52305, 52306, 52307
System Components	Document Number
DVC Digital Voice Command Manual	52411
DAL Device Reference Document	52410
DVC-RPU Manual	50107425-001
DVC-RPU UL Listing Document	50107424-001
DS-DB Digital Series Distribution Board and Amplifier Manual	53622
DAA2 and DAX Amplifiers Manual	53265
Annunciator Control System Manual	15842
Annunciator Fixed Module Manual	15048

Table 1.3 Related Documentation (1 of 2)

AFM-16A Annunciator Fixed Module Manual	15207
ACM-8R Annunciator Control Module Manual	15342
LCD-80 Manual	15037
LCD2-80 Manual	53242
FDU-80 Remote Annunciator Manual	51264
LDM Series Lamp Driver Annunciator Manual	15885
SCS Smoke Control Manual (Smoke and HVAC Control Station)	15712
FireVoice-25/50ZS & FireVoice 25/50ZST Manual	52290
FirstCommand Emergency Communication System	LS10001-001NF-E
RPT-485W/RPT-485WF EIA-485 Annunciator Loop Repeater Manual	15640
DPI-232 Direct Panel Interface Manual	51499
TM-4 Installation Document (Reverse Polarity Transmitter)	51490
UDACT Manual (Universal Digital Alarm Communicator/Transmitter)	50050
UDACT-2 (Universal Digital Alarm Communicator/Transmitter) Listing Document	54089LD
UDACT-2 Manual (Universal Alarm Communicator/Transmitter)	54089
ACT-2 Installation Document	51118
RM-1 Series Remote Microphone Installation Document	51138
RA100Z Remote LED Annunciator Installation Document	156-0508

Table 1.3 Related Documentation (2 of 2)

1.2.4 Shortcuts to Operating Functions



To the left of each program function, you'll find a keypad shortcut, which contains a series of keypad entries required to access the program function. All shortcuts start with the control panel in normal operation.



For example, the keypad shortcut to the left shows how to enter the Read Status function with the control panel in normal operation.

1.3 Introduction to the Control Panel

The NFS2-640 is an intelligent, field-programmable Fire Alarm Control Panel. Field-programming the control panel lets you customize the fire alarm system by selecting and setting program options for intelligent/addressable detectors and modules, and Notification Appliance Circuits (NACs).

This manual provides information for programming using the NFS2-640 keypad connected to the control panel. VeriFire™ Tools must be used for programming if no keypad is used, or if a network control annunciator is used as the keypad in either a network or standalone application. Refer to VeriFire™ Tools for information on programming without the NF2S-640 keypad, and the *NF2S-640 Installation Manual* and *NCA-2 Manual* for installation information.

For details on control panel operation, refer to the *NFS2-640 Operations Manual*.

The NF2S-640 provides two methods for field-programming the control panel:

- Using the built-in “Program Change” interface
- The VeriFire™ Tools Programming Utility

The benefits of each method are listed below:

Programming method	Benefits	Refer to
Program Change	Speed and convenience of putting the control panel on line quickly (using the Autoprogram function) and changing programming information.	Section "Programming" on page 13
VeriFire™ Tools Programming Utility	Efficient means of creating and editing programs that require a lot of data entry.	Product documentation & Software help file

1.4 Features

Programming features include the following:

- Ease-of-use – Field program the control panel without needing special software skills.
- Autoprogram option – Automatically detects newly installed, addressable devices, allowing quicker installation.
- Local programming – program directly from the control panel keypad to reduce installation time.
- PC programming – input long data entry programming information on a PC; transfer programming data between a PC and the control panel using VeriFire™ Tools programming utility.
- Security – use passwords to control access to the control panel and protect memory.
- 80-Character (2x40) Liquid Crystal Display – view programming and device information on the control panel.

1.5 How to Enter a Password

The control panel provides two types of selectable passwords:

- Program Change
- Status Change

Listed below are uses and the factory-setting for each password type:

Table 1.4 Programming Passwords

Password type	Use to	Factory Setting
Program Change (high level)	Enter Program Change option to program essential control panel functions, including basic system functions and utility options.	00000
Status Change (low level)	Enter Status Change option to program minor functions.	11111

From the “SYSTEM NORMAL” screen: Press ENTER, press **1** (the password screen will display). Enter a password, then press ENTER

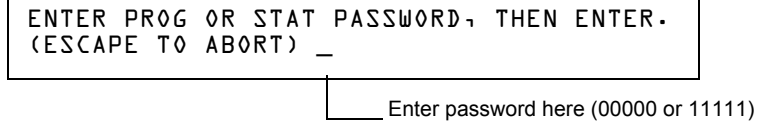

Figure 1.1 Password Screen

In Program Change or Status Change, the control panel does the following:

- Activates the System Trouble relay
- Shuts off the panel sounder
- Flashes the SYSTEM TROUBLE LED, which continues to flash while programming

For security purposes, passwords can be changed. To do so, follow the instructions in “Change a Password (3=passwd)” on page 25.



NOTE: The Read Status selection, which does not require a program password, is covered in the *NF2S-640 Operations Manual*.



NOTE: The NF2S-640 continues to monitor and report alarms in programming mode, except in autoprogramming.

Section 2: Programming

2.1 Overview

Program Change is the programming level that lets you change the essential control panel functions, such as point programming, changing passwords, changing system functions. Included are four options: Basic Program, Network, FlashScan Poll, and Utility Program.

The structure of the Program Change option is shown below:

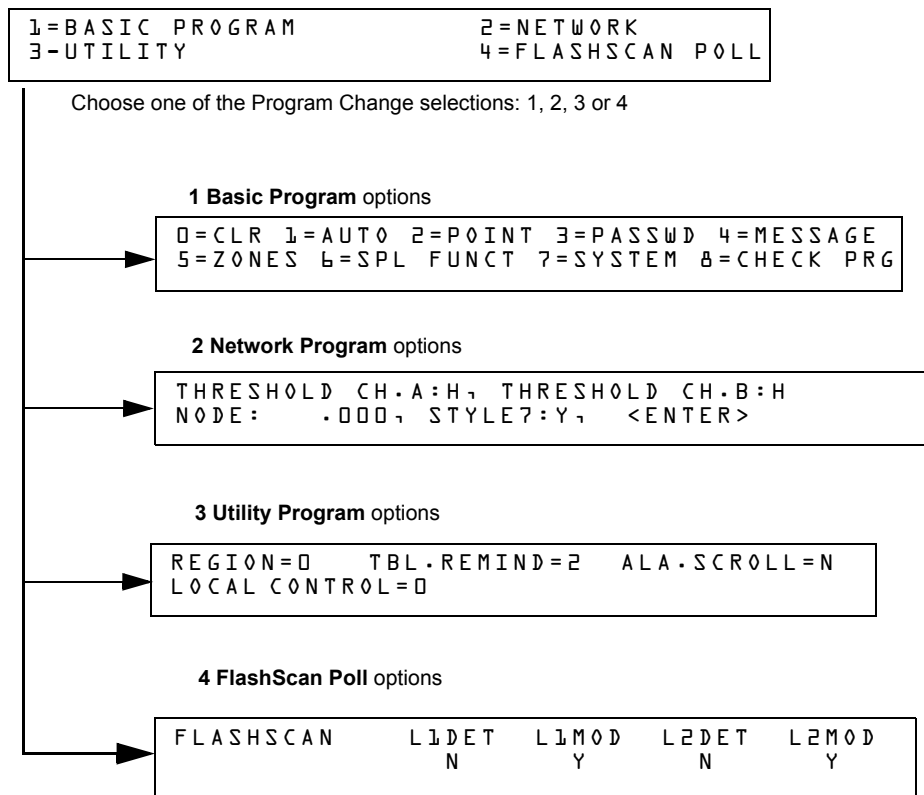

Figure 2.1 Program Change Selections

This section contains instructions and sample screens for using the Programming selections:

- **Basic Program** The Basic Program lets you program essential functions, such as clearing the program, Autoprogramming the system, programming points, and setting system functions. Refer to “Basic Program” on page 14.
- **Network Program** The Network Program allows programming of network channel thresholds, network node number, and wiring style. “The Network Program” on page 47.
- **Utility Program** The Utility Program screen provides selections for selecting a Trouble Reminder per NFPA, a Region setting, and enabling or disabling local control of the ACKNOWLEDGE/SCROLL DISPLAY, SIGNAL SILENCE, SYSTEM RESET and DRILL keys. Refer to “The Utility Program” on page 48.
- **FlashScan Poll** The FlashScan Poll screen provides the option for selecting between CLIP (Classic Loop Interface Poll) and FlashScan Poll. Refer to “FlashScan Poll” on page 49.

2.2 How to Enter Programming

To enter Program Change, follow these steps:

1. At the “SYSTEM NORMAL” screen, press the ENTER key. The control panel displays the “Entry” screen, as shown below:

```
1=PROGRAMMING          2=READ STATUS ENTRY
(ESCAPE TO ABORT)
```

2. At the “Entry” screen, press the 1 key. The control panel displays the “Enter Password” screen as shown below:

```
ENTER PROG OR STAT PASSWORD, THEN ENTER.
(ESCAPE TO ABORT) _
```

3. Enter your Program Change password (See “How to Enter a Password” on page 11). The control panel displays the “Program Change Selection” screen, as shown below:

```
1=BASIC PROGRAM        2=NETWORK
3=UTILITY              4=FLASHSCAN POLL
```

4. Select a Program Change selection: **1, 2, 3** or **4**.

2.3 Basic Program

From the “Program Change Selection” screen, press the 1 key to display the “Basic Program” screen which provides nine (9) options as shown below:

```
0=CLR  1=AUTO  2=POINT  3=PASSWD  4=MESSAGE
5=ZONES 6=SPL FUNCT 7=SYSTEM 8=CHECK PRG
```

Press the number of any one of the nine (9) options as detailed below

Option 0=CLR - Clears all existing user programming. For details, refer to How to Clear Memory (0=CLR) on page 15. Note: The user is prompted to double-check that this is what is really wanted.

Option 1=AUTO - Add or remove addressable devices to the control panel program. For details, refer to How to Autoprogram the Control Panel (1=AUTO) on page page 15.

Option 2=POINT - Modify or delete a point. For details, refer to “How to Modify or Delete a Point (2=POINT)” on page page 19.

Option 3=PASSWD - Change the Program Change or the Alter Status password. For details, refer to “How to Change a Password (3=PASSWORD)” on page page 25.

Option 4=MESSAGE - Edit the 40-character message that displays on the first line. For details, refer to “How to Create a System Message (4=MESSAGE)” on page page 26.

Option 5=ZONES - Edit the 20-character custom zone label for zones 01-99. For details, refer to “How to Create a Custom Zone Label (5=ZONE)” on page page 27.

Option 6=SPL FUNCT - Program Releasing Zones and Special Zones. For details, refer to “How to Program Special Zones (6=SPL FUNCT)” on page page 27.

Option 7=SYSTEM - Program Global System Functions. For details, refer to “How to Change Global System Functions (7=SYSTEM)” on page page 31.

Option 8=CHECK PRG - Check the program for errors. For details, refer to “How to Check the Program for Errors (8=check prg)” on page 47.

2.3.1 Clear Memory (0=CLR)



Program Change
Password



The Clear option removes all programming information from control panel memory. If installing the control panel for the first time, use option 0 to clear control panel memory. To do so, follow these steps:

1. From the “Basic Program” screen, press the **0** (zero) key to display the Clear Program screen. The control panel prompts for verification as shown below:

```
PRESS ENTER TO CLEAR ENTIRE PROGRAM
OR ESCAPE TO ABORT
```

2. Press the ENTER key to clear control panel memory or press the ESC key to exit the screen without clearing.

2.3.2 Autoprogram the Control Panel (1=AUTO)

Purpose

The Autoprogram option identifies all addressable devices connected to the control panel. Devices include addressable detectors and modules connected to SLC 1 or SLC 2, and NACs. You can use the Autoprogram option to create a new program and add or remove devices. A summary of the Autoprogram functions, when to use the functions, and where to find information on using the functions is found below:

Autoprogram Function	Control Panel Configuration	Refer to...
Create a new program for the control panel	A new control panel or a control panel with no existing program in memory.	“Create a New Program for the Control Panel” on page 15
Add one or more SLC-connected detectors and modules to an existing program	A program exists in memory and you want to add a detector or module to the existing program—without modifying information for existing detectors and modules.	“Add a Device to the Program” on page 16
Remove one or more SLC-connected detectors and modules from an existing program	A program exists in memory and you want to remove an installed detector or module from the existing program—without modifying information for existing detectors and modules.	“Remove a Device from the Program” on page 17
View system defaults	A program exists in memory and you want to view system settings assigned during Autoprogram, such as custom labels, passwords, and so on.	Page 19 “Change Autoprogram Default Value” to see the system defaults

Create a New Program for the Control Panel



Program Change
Password



This section covers how to use the Autoprogram option to create a new program for the control panel. The control panel will identify all addressable detectors and modules connected to the SLC.

To create a new program for the control panel, follow these steps:

1. Use the Clear option to clear program information from memory. For instructions on clearing memory, refer to “How to Clear Memory (0=CLR)” on page page 15.



NOTE: Once Step 1 is completed, Step 2 will cause the panel to assess whether a loop is comprised of all FlashScan devices or not. If they are all FlashScan, autoprogramming will change the loop setting to FlashScan if it was not already at that setting. If the devices are not all FlashScan, autoprogramming will not make a change to the default setting of CLIP. (See “FlashScan Poll” on page 49 for FlashScan settings.)

2. From the “Basic Program” screen, press the **1** key to start Autoprogram. While the control panel scans the system to identify all SLC devices and NACs, it displays the following screen:

```
AUTOPROGRAM           PLEASE WAIT
```

When the autoprogram is finished identifying SLC devices and NACs, it displays a summary screen that gives a count of all the devices it has located. Refer to the following screen for an example of this display.

```
L1:010Dets, 159Mods  L2:159Dets, 159Mods
SB L1:000, L2:159    Bells: 04
```

SB represents detectors with B200 series sounder bases. Refer to VeriFire Tools for B200 sounder base programming.

3. Press ENTER. All devices are automatically accepted during initial autoprogramming. The following screen displays briefly, followed by the SYSTEM NORMAL screen.

```
ACCEPT ALL DEVICES    Please Wait!!!
```

To edit the autoprogramming default values for a point, refer to “How to Modify or Delete a Point (2=POINT)” on page 19.

To edit the autoprogram default values assigned to all modules and detectors during autoprogramming, refer to “Change Autoprogram Default Values” on page 18.

Add a Device to the Program

You can also use the Autoprogram option to add addressable devices to the control panel program.



NOTE: When using the Autoprogram option with an existing program, the control panel does not change program information for installed and programmed devices. However, it will assess whether a loop contains all FlashScan devices and change the loop setting to FlashScan if necessary.

The following steps describe how to add a new detector at SLC address 1D147 with 10 detectors in the existing program:

1. Physically install the addressable detector to SLC 1 at address 147 (for instructions, refer to the *NFS2-640 Installation Manual* and the installation document that comes with the detector).
2. From the “Basic Program” screen, press the **1** key to start Autoprogram. The Autoprogram Prompt screen appears in the LCD display as the control panel identifies addressable devices. When finished identifying addressable devices, the control panel displays information for the new detector at SLC address 1D147 on the LCD display as shown below:

```
PROGRAM SMOKE (PHOTO) DETECTOR ADDR 1D147
03  _ _ _ _ _ A B P B * * 1D147
```

- Press the ENTER key to add detector 147 to the program with the default program information. If you want to change the default information, use the programming keys to do so, then press the ENTER key to add detector 147 to the program. The Autoprogram Summary screen appears. You can verify addition of the detector to the program by noting the new count of detectors as shown below:

Note that the number of detectors increases (in this example from 10 to 11) to show the addition of the detector to SLC 1.

```

L1: 0111Dets, 159Mods  L2: 159Dets, 159Mods
SB                      Bells: 04

```

- Press the ENTER key, then press the esc key to save the program in memory and return to the “Basic Program” screen).

Remove a Device from the Program

You can also use the Autoprogram option to remove addressable detectors and modules from the control panel program.



NOTE: When using the Autoprogram option with an existing program, the control panel does not change program information for installed and programmed devices.

The following steps describe how to delete a detector at SLC address 1D133 with 11 detectors connected to SLC 1 in the existing program:

- Disconnect and remove the detector from SLC 1 at address 1D133.
- From the “Basic Program” screen, press the 1 key to start Autoprogram. The Autoprogram Prompt screen displays while the control panel identifies addressable devices.
- When finished identifying addressable devices, the control panel displays a screen, indicating a missing detector at SLC address 1D133 as shown below:

Type Code

```

PROGRAM SMOKE (ION) DETECTOR ADDR 1D133
DEVICE NOT ANSWERING DELETE FR MEM? 1D133

```

SLC loop number
D (detector) or M (module)
Three-digit address (001-159)

- Press the ENTER key to delete detector 1D133 from the program. The Autoprogram Summary screen appears. You can verify removal of the detector from the program by noting the new count of detectors as shown below:

Note that the number of detectors decreases (from 11 to 10) to show the removal of the detector from SLC 1.

```

L1: 0110Dets, 159Mods  L2: 159Dets, 159Mods
SB                      Bells: 04

```

- Press the ENTER key, then press the ESC key to save the program in memory and return to the “Basic Program” screen.

Change Autoprogram Default Values

To assign system default values from the basic program screen, Press **0** (clear), then press **1** (autoprogram). Refer to the chart below for default values and how to modify them.

Table 2.1 Autoprogram Defaults (1 of 2)

Function	Default Values	To Alter, refer to
Software Zones 01-99	Default custom label "Zone xx" where xx is the number of the zone Note: Zone 00 is reserved for a general alarm.	"How to Create a Custom Zone Label (5=ZONE)" on page 27
F0	PRG PRESIGNAL FUNCT PRESIGNAL DELAY DELAY=180 PAS=NO F00	"F0 (Presignal/PAS) The Presignal screen provides fields for changing the delay time or PAS. For details on Presignal selections, refer to "Presignal and PAS Time" on page 92. From the Special Function Change screen, press the F key, then press the 0 key to display the Presignal Function screen." on page 29
Releasing Zones R0-R9	PRG RELEASE FUNCT RELEASE CONTROL DELAY=00 ABORT=ULI CROSS=N SOK=0000	"R0-R9 (Releasing Functions) The Releasing Function screen provides fields for changing releasing functions: Delay Timer, Abort Switch, Cross Zone, and Soak Timer. For details on releasing applications, refer to "NFPA Releasing Applications" on page 61." on page 29 and "How to Program a Releasing Zone" on page 61.  NOTE: The FCM-1-REL has an inherent two second delay, which must be factored into the DELAY TIME and SOK (soak time) entries.
F5 and F6	PRG TIME FUNCTION TIME CONTROL ON=**:** OFF=**:** DAYS=*****	"F5-F6 (Time Control Functions) The Time Control screen provides fields for changing the start time, stop time, or days of the week. For details on time selections, refer to "Time Control Zones" on page 93. From the Special Function Change screen, select F5 or F6 to display the Time Control screen:" on page 30
F7	PRG HOLIDAY FUNCTION **/** **/** **/** **/** **/** **/** **/** **/** **/**	"F7 (Holiday) The Holiday screen provides fields for specifying up to nine holiday dates. For details on holiday selections, refer to "Time Control Zones" on page 93. From the Special Function Change screen, press F7 to display the Holiday screen:" on page 30
F8	PRG CODING FUNCTION CODE TYPE MARCH TIME F08	"F8 (Coding Function) The Coding Function screen provides fields for specifying one of the following coding functions: March Time, Two-stage, California, Temporal, Two-Stage Canada (3 minutes), Two-Stage Canada (5 minutes), Two-Stage Canada Manual, System Sensor Strobe, Gentex Strobe, and Wheelock Strobe. For details on selecting coding functions, refer to "Coding Functions for NACS" on page 93. From the Special Function Change screen, press F8 to display the Coding Function screen:" on page 30
F9	PRE-ALARM FUNCT ALERT F09	"F9 (Pre-Alarm) The Pre-Alarm screen provides fields for programming the Alert or Action Pre-Alarm functions. For details on Pre-Alarm selections, refer to "Pre-Alarm" on page 99. From the Special Function Change screen, press F9 to display the Pre-Alarm screen:" on page 31
System Parameters	SIL INH=0000 AUTO=0077 0 VERIFY=30 USA TIME TERM=N AC_DLY=Y LocT BLINK=01 ST=4 ACS=N	"How to Change Global System Functions (7=SYSTEM)" on page 31
Passwords	Default programming passwords are: Program Change=00000 Status Change=11111	"How to Change a Password (3=PASSWD)" on page page 25
SYSTEM NORMAL message	(YOUR CUSTOM SYSTEM MESSAGE HERE) SYSTEM NORMAL 10:23A 041508 Tue A message, along with the current day, time, and date, that displays on the second line of the LCD display during normal operation.	Note: The second line, "SYSTEM NORMAL", is a standard system message that you cannot change

Table 2.1 Autoprogram Defaults (2 of 2)

Function	Default Values	To Alter, refer to
System Message	(YOUR CUSTOM SYSTEM MESSAGE HERE) SYSTEM NORMAL 10:23A 041508 Tue The first line of the LCD display contains 40 blank characters for a custom message.	"How to Create a System Message (4=MESSAGE)" on page 26
IP ACCESS	Default setting is zero (0), IP Access not enabled.	"The Utility Program" on page 48
DCC Mode	Default setting is N, no DCC participation.	"The Utility Program" on page 48

2.3.3 Modify or Delete a Point (2=POINT)

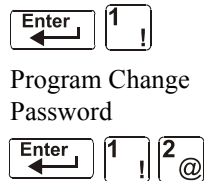

Program Change Password

After programming all SLC-connected devices into the system, you can modify or delete points. From the "Basic Program" screen, press the **2** key to display the Point Programming screen:

```
POINT PROG.          1=MODIFY POINT
2=DELETE POINT
```

To modify a point for a detector, module, or NAC: press the **1** key to display the "Modify Point" screen.

NOTE: When programming points, take the following into design consideration:
 Each general zone must be dedicated to a single event type (i.e. Fire, MN, Security, etc.)
 Map inputs only to general zones designed for the input's event type. For example, map mass notification devices to general zones designed for mass notification.
 Outputs can be mapped to multiple general zones that are dedicated to different event types. For instance, a single output can be mapped to an MN general zone and a Fire general zone.

To delete a point for a detector, module, or NAC: press the **2** key to display the "Delete Point" screen.

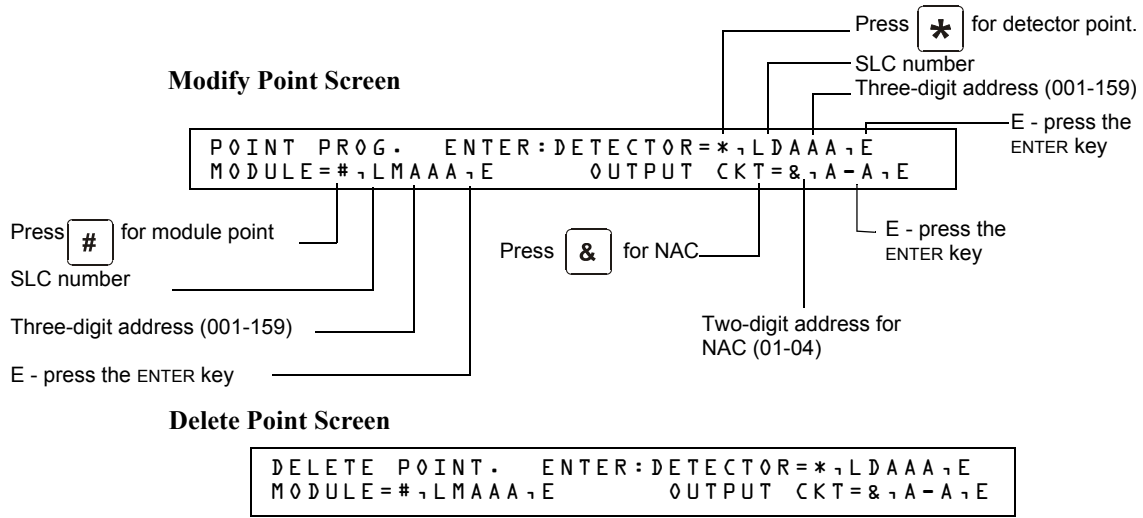

The Modify Point and Delete Point screens let you edit or delete points for a detector, a monitor or control module, or NAC. To select a point, follow these steps:

To select	Do the following	Refer to
an addressable detector	Press * Type the SLC number (1 or 2) and detector (D) and address (001-159) Press Enter	"Modify an Addressable Detector Point" on page 20.
an addressable monitor module	Press # Type the SLC number (1 or 2) and module (M) and address (001-159) Press Enter	"Modify an Addressable Monitor Module Point" on page 22.
an addressable control module	Press # Type the SLC number (1 or 2) and module (M) and address (001-159) Press Enter	"Modify an Addressable Control Module Point" on page 23.
a NAC	Press & Type the NAC address (01-04) Press Enter	"Modify NAC Points" on page 24.

The next four sections describe how to program the points selected.

Modify an Addressable Detector Point

This section contains a sample detector programming screen, detector default selection, and instructions for modifying a detector point. Autoprogram default values for a detector are shown:

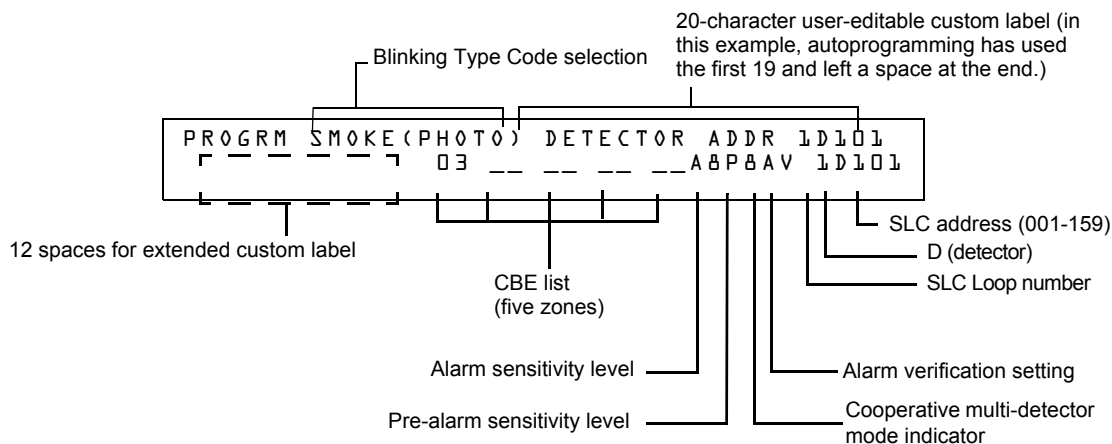

Table 2.2 Detector Program Values

Field	Description	Set as Follows
Type Code	Detector function specification - SMOKE(PHOTO) in example.	Press the NEXT or PREVIOUS Selection keys to scroll through valid detector Type Code selections. See F.4.2 on page 112 for lists and descriptions.
Custom Label	20 character custom label.	Change by placing the cursor into the first space of the field using the arrow keys, then typing the descriptor. DETECTOR ADDR 1D101 is the autoprogram default custom label for the detector at address 101 on SLC 1.

Table 2.2 Detector Program Values

Field	Description	Set as Follows
Extended Label	12 character custom label extension.	See "Custom Label" above. Note that spaces must be input by the user, including any space necessary between the custom and extended label fields. An 80-column printout will run the two fields together.
CBE List	Five zones can be listed - one zone, Z03, is shown in the example. Up to 4 more could be added to this detector.	Zones can be changed or added to the CBE list by placing the cursor in the zone field using arrow keys, then typing. Defaults: Zone 01 (Heat detectors) Zone 02 (Ion detectors) Zone 03 (Photo detectors, Beam detectors) Zone 04 (Laser detectors) Zone 05 (Multisensor)
Alarm Sensitivity	The alarm sensitivity level, with 9 the least sensitive alarm level and 1 the most sensitive alarm level.	Refer to Table C.2 on page 101 for settings. Select by placing the cursor in the field using the arrow keys, then either pressing the NEXT or PREVIOUS keys to make the selection, or typing the value. Defaults: A8 (Photo) A6 (Ion) A6 (Laser) A5 (Multisensor)
Pre-alarm level	Shows the Pre-Alarm level setting—a number between 0 and 9—as follows: 0 – no Pre-Alarm 1 – self optimizing 2 – most sensitive Pre-Alarm level 9 – least sensitive Pre-Alarm level	Refer to Table C.2 on page 101 for settings. Select by placing the cursor in the field using the arrow keys, then either pressing the NEXT or PREVIOUS keys to make the selection, or typing the value. Defaults: P8 (Photo) P6 (Ion) P6 (Laser) P5 (Multisensor)
Cooperative Multi-detector mode	Indicates the cooperative multi-detector mode (A in the example).	Select by placing the cursor in the field using the arrow keys, then either pressing the NEXT or PREVIOUS keys to make the selection, or typing the value. * = OFF (Default) A combines the detector's alarm decision with the next address above B combines the detector's alarm decision with the next address below C combines the detector's alarm decision with the next address above and the next address below
Alarm verification	Indicates the alarm verification setting (V in the example).	Indicates Alarm Verification (V=on, *=off). Select by placing the cursor in the field using the arrow keys, then pressing the NEXT or PREVIOUS keys to make the selection. Refer to "Interpreting a Detector Status Display or Maintenance Report" on page 104 for more information on the alarm verification feature. Note: Do not use this setting when an alarm activation requires activation of two or more automatic detection devices.

Modify an Addressable Monitor Module Point

When you select a point address, the control panel returns a screen that displays information about the point. Below is an example of information for a monitor module (2M101) in the LCD display:

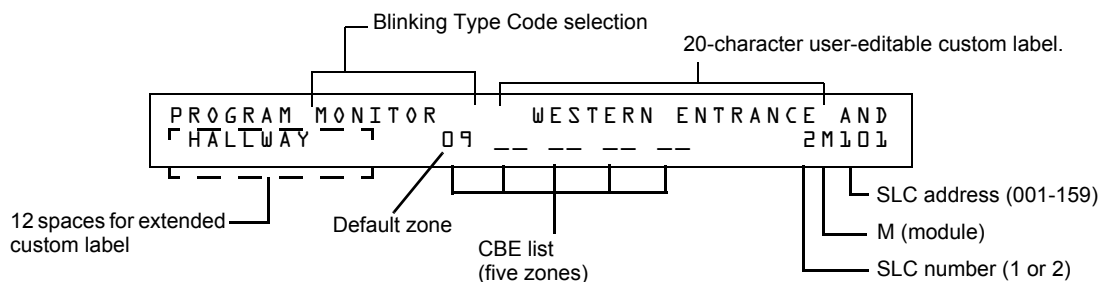

Table 2.3 Modifying Monitor Module Programming Selections

Field	Description	Set as Follows
Type Code	Monitor Module function specification - MONITOR in example.	Press the NEXT or PREVIOUS Selection keys to scroll through valid monitor module Type Code selections. Lists and descriptions are in See Table F.2 on page 114.
Custom Label	20 character custom label.	Change by placing the cursor into the first space of the field using the arrow keys, then typing the descriptor. Note: Spaces must be input by the user, including any space necessary between the custom and extended label fields. An 80-column printout will run the two fields together.
Extended Label	12 character custom label extension.	See "Custom Label" above.
CBE List	Five zones can be listed - one zone, Z09, is shown in the example. Up to 4 more could be added to this module.	Zones can be changed or added to the CBE list by placing the cursor in the zone field using arrow keys, then typing. See Table 2.4 on page 22 for defaults.

When finished modifying a point, press the ENTER key; then press the NEXT or PREVIOUS key to select another point.

Monitor Module Default Zone Assignments

Listing of the monitor module address range and the default zone assignment for each range:

Table 2.4 Monitor Module Default Zones

Monitor Module Address	Zone Default
01 through 19	Z04
20 through 39	Z05
40 through 59	Z06
60 through 79	Z07
80 through 99	Z08
100 through 119	Z09
120 through 139	Z10
140 through 159	Z11

Modify an Addressable Control Module Point

When you select a point address for modification, the control panel returns a screen that displays information about the point. For example, the illustration below shows sample information for a control module (2M101) in the LCD display.

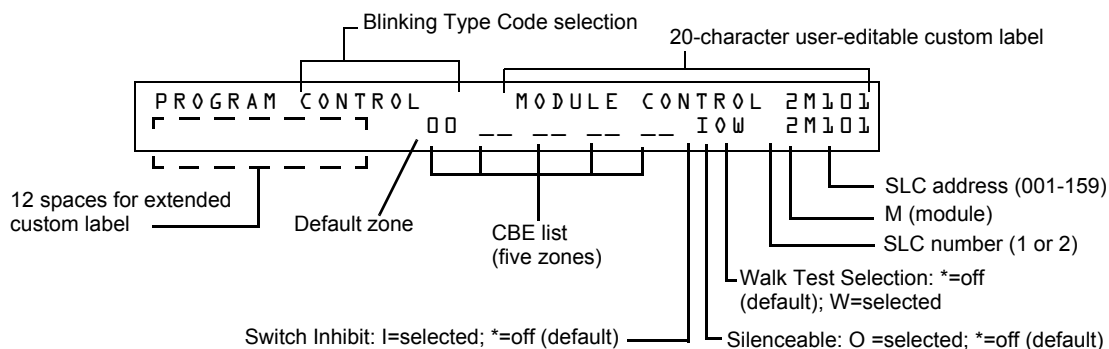

NOTE: On a control module, the default zone is always set to Zone 00 (general alarm).

To modify a point, follow these steps. A blinking cursor indicates the selected field.

1. From the programming screen, use the arrow keys to move to a field that you want to modify. See below for descriptions and settings.

Table 2.5 Modifying Control Module Programming Selections (1 of 2)

Field	Description	Set as follows:
Type Code	Specifies the function of the control module	Press the NEXT or PREVIOUS Selection keys to scroll through valid control module Type Code selections (listed in Table F.3 on page 115)
Custom Label	20 character custom label.	Change by placing the cursor into the first space of the field using the arrow keys, then typing the descriptor. Note: Spaces must be input by the user, including any space necessary between the custom and extended label fields. An 80-column printout will run the two fields together.
Extended Label	12 character custom label extension.	See "Custom Label" above.
CBE list	Up to five software zones can be entered to define the output responses of the control module based on various initiating conditions (events)	Type the number of up to five zones, including E0-E9, F0-F9, L0-L9, R0-R9, and zones 00-99. The first zone default is Z00 (general alarm).
Switch Inhibit	Specifies if an operator can manually activate an output	Type one of the following entries. I = Switch Inhibit enabled * = no switch inhibit (default for all but releasing circuits)
Silenceable	Specifies if an operator can manually silence an activated output	Type one of the following entries. * = output nonsilenceable F = silenceable, resound by fire alarm U = silenceable, resound by supervisory alarm B = silenceable, resound by security alarm T = silenceable, resound by trouble O = silenceable, does not resound If the "Strobe" Type ID is used with System Sensor, Gentex or Wheelock Strobe synchronization, "*" will silence the horn portion only, and resound will occur only by fire alarm. F, U, B, T, or O will silence the entire circuit, and resound will occur according to the above definitions.

Table 2.5 Modifying Control Module Programming Selections (2 of 2)

Field	Description	Set as follows:
Walk Test	Specifies if outputs sound during Walk Test	Type one of the following entries. W = devices sound (Basic Walk Test) * = devices do not sound (Silent Walk Test) (default)

- When finished modifying a point, press the ENTER key; then press the NEXT or PREVIOUS key to select another point.

Modify NAC Points

Modifying NACs (four NACs on the NFS2-640) is like modifying control modules—except for the Type Code and device address.

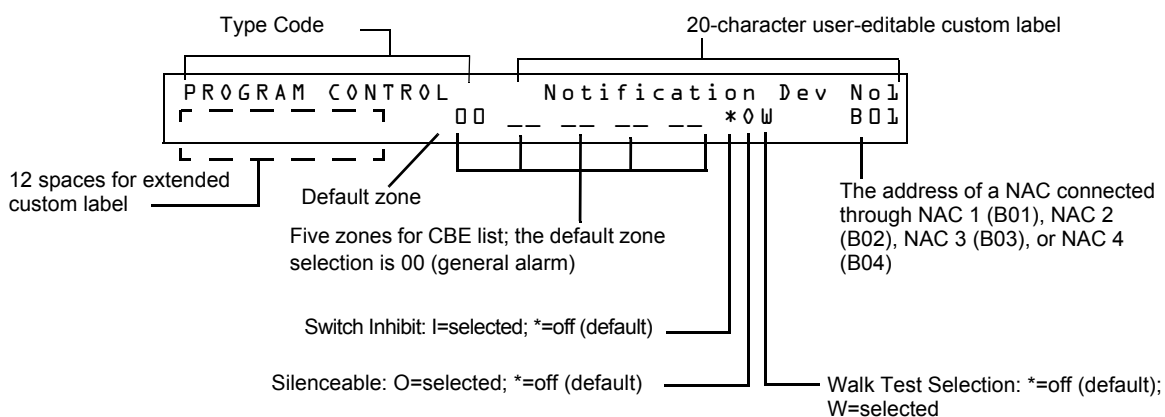

To modify a point, follow these steps. A blinking cursor indicates the selected field.

- From the programming screen, use the arrow keys to move to a field that you want to modify and refer to information below for descriptions and settings.

Table 2.6 Modifying a NAC Programming Selections (1 of 2)



Field	Description	Set as follows:
Type Code	Specifies the function of the NAC.	Press the NEXT or PREVIOUS Selection keys to scroll through the NAC Type Code selections (listed in Table F.4 on page 116)
Custom Label	20 character custom label.	Change by placing the cursor into the first space of the field using the arrow keys, then typing the descriptor. Note: Spaces must be input by the user, including any space necessary between the custom and extended label fields. An 80-column printout will run the two fields together.
Extended Label	12 character custom label extension.	See "Custom Label" above.
CBE zones	Specifies up to five software zones to define the output responses of the NAC based on various initiating conditions (events)	Type the numbers of up to five zones, including E0-E9, F0-F9, L0-L9, R0-R9, and zones 00-99. The first zone default is 00 (general alarm)
Switch Inhibit	Specifies if an operator can manually activate an output	Type in one of the following values. I = Switch Inhibit enabled * = Switch Inhibit disabled (default for all but releasing circuits)

Table 2.6 Modifying a NAC Programming Selections (2 of 2)

Field	Description	Set as follows:
Silenceable	Specifies if an operator can manually silence an activated output	Type in one of the following values. * = output nonsilenceable F = silenceable, resound by fire alarm U = silenceable, resound by supervisory alarm B = silenceable, resound by security alarm T = silenceable, resound by trouble O = silenceable, does not resound If the "Strobe" Type ID is used with System Sensor, Gentex or Wheelock Strobe synchronization, "*" will silence the horn portion only, and resound will occur only by fire alarm. F, U, B, T, or O will silence the entire circuit, and resound will occur according to the above definitions.
Walk Test	Specifies if outputs sound during Walk Test	Type in one of the following values. W = devices sound (Basic Walk Test) - default * = devices do not sound (Silent Walk Test)

- When finished modifying a point, press the ENTER key; then press the NEXT or PREVIOUS key to select another point.

2.3.4 Change a Password (3=PASSWD)

 Program Change
 Password

Password Change lets you select a custom Program Change (high level) or Status Change (low level) password. From the "Basic Program" screen, press the **3** key to display the "Change Password" screen.









```

CHANGE PASSWORD      * , NNNNN , E = PROGRAM
# , NNNNN , E = STATUS
    
```

Entry area for new password

To change a password, follow the instructions below:

Table 2.7 Changing a Password

To	Press	Then
Change the Program Change password		Enter the new Program Change password. Use five digits, no characters.
Change the Status Change password		Enter the new Status Change password. Use five digits, no characters.
Save the password		The Verify Password screen appears. Press ENTER to verify.
Leave the Change Password screen without changing a password		The Basic Program screen appears.

A Forgotten Password?

If a password is entered incorrectly, the panel will respond by displaying an INCORRECT PASSWORD message and a code. The programmer may hit escape and reenter the password correctly. However, if the password has been forgotten, record the code and contact Notifier. After proper authentication, the original password can be determined by deciphering the code. An example of an INCORRECT PASSWORD display is given below:

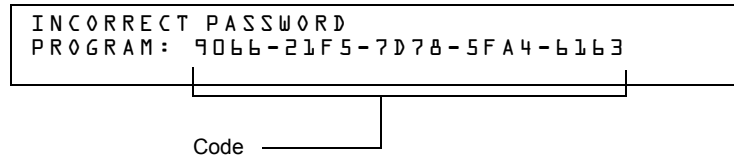

2.3.5 Create a System Message (4=MESSAGE)

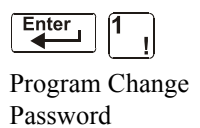

The Message option lets you create a 40-character custom System Message that displays on the first line of the “SYSTEM NORMAL” screen as shown below:

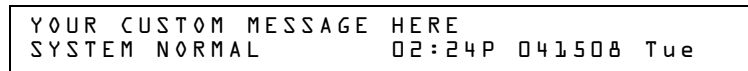

From the “Basic Program” screen, press the 4 key to display the “System Message Change” screen:

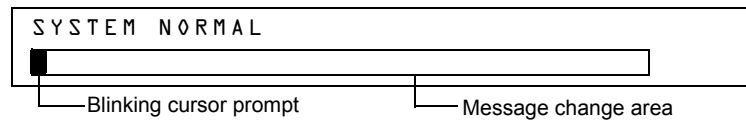

To create the system message, follow these guidelines:



- Enter one character at a time, indicated by the blinking cursor on the second line of the display.
- Enter up to 40 characters maximum.

Instructions for entering characters in the Message Change screen:



Table 2.8 Creating Messages

To	Do this
Change a blinking character	Enter a character from the keypad
Move to the next character	Press
Enter lower case characters	Press , then press the character of your choice.
Enter additional characters ! @ = , % : \ . ! ?	Press , then press a number key as follows: For example, press , then press the 3 () key to enter a “=” character.
Save the new message	Press

2.3.6 Create a Custom Zone Label (5=ZONE)

 
 Program Change
 Password

The Zone option lets you change the custom label assigned to zones 1-99. From the “Basic Program” screen, press the **5** key to display the “Zone Change” screen as shown below:

blinking cursor prompt

CHANGE ZONE LABEL SELECT ZONE 01-99 █ ENTER UP TO 20 CHAR
--



Custom zone label (characters 21-40)

The zone number displays in the first line, characters 39 and 40. When changing a zone label, follow these guidelines.



- For single-digit numbers, enter a leading zero before the digit.
- Enter an alphanumeric zone label into line 2, characters 21–40.

To change a custom label for a zone, follow these instructions:

Table 2.9 Create or Change a Custom Zone Label

To	Do this
Change a zone label	Enter a new zone label from the keypad.
Save the zone label in memory	Press  . The program stores the zone label in memory and displays the Zone Change screen with all fields blank.
Leave the Zone Change screen without changing a zone label	Press  . The display returns to the Program Change screen.

2.3.7 Program Special Zones (6=SPL FUNCT)

 
 Program Change
 Password

The Special Zone Change option lets you change the program for Special Zones F0-F9, Releasing Zones R0-R9, FA (Verification), FB (Custom drill zone) or FC (CO Alarm). From the “Basic Program” screen, press the **6** key to display the “Special Function Change” screen as shown below:

SPECIAL FUNCTION: F0=PRESIG R0-R9=REL F5-F6=TIME F7=HOL F8=CODE F9=PRE-ALARM

Special Zone Descriptions

Descriptions for each Special Zone that appears in the “Special Function Change” screen are detailed below:



NOTE: Special Zones F0-F9 appear in the CBE list of a device as ZF0-ZF9. For example, if you list F0 for a detector, one of the five zones in the CBE list of the detector will display as ZF0.

Table 2.10 Summary of Special Zones

Special Zone	Lets you
F0=PRESIG	Select a Presignal Delay Timer and select PAS (Positive Alarm Sequence)
F5-F6=TIME	Specify Time Control functions such as the start time, stop time, or days of the week
F7=HOL	Specify up to nine holiday dates. An F7-programmed device activates on the specified holiday dates
F8=CODE	Specify one of the following coding function selections: March Time, Temporal, California, Two-Stage, Two-Stage Canada (3 minute or 5 minute), Two-Stage Canada Manual, System Sensor Strobes, Gentex Strobes, or Wheelock Strobes. F8 only takes effect if you program one or more NACs to F8
F9=PRE-ALARM	Select a Pre-Alarm level: Alert or Action
FA (ZF10*)	Turn on when detector in verification mode. This is a fixed point and is not programmable
FB (ZF16*)	Turn on if custom drill set to Y and the panel in Drill mode
FC (ZF18*)	Turn on when a CO alarm occurs
FD (ZF20*)	Turns on when a mass notification alarm occurs (Not applicable for FirstCommand applications)
FE (ZF21*)	Turns on when a mass notification supervisory occurs
FF (ZF22*)	Turns on when a mass notification trouble occurs
NOTE: Special Function Zones FA through FF are not field programmable.	
R0-R9=REL	Program up to ten Releasing Zones, each with a selection for a Delay Timer, an Abort Switch, a Cross Zone selection, or a Soak Timer
* VeriFire Tools settings	

Mass Notification

When used for mass notification, special zones ZF20, ZF21, and ZF22 can be used to signal the MN event.

NOTE: During local or network Walk Test, activating a Mass Notification device will activate associated special function zones according to CBE programming and simulate a Mass Notification event. Any network nodes, zones, or devices not participating in Walk Test will not participate in the simulated Mass Notification event.

Special Zones F1-F4

The control panel also provides four Special Zones, F1-F4, which are outputs that do not appear on the Special Function Change screen. You can program Special Zones F1 to F4 into the CBE of an output device. Descriptions of F1, F2, F3, and F4 are detailed below:

To view the status of Special Functions F1-F4, use the Read Status function (refer to the *NFS2-640 Operations Manual*).

Table 2.11 Special Output Functions F1-F4 (1 of 2)

Special Function	Specifies
F1 (Trouble less AC)	An output programmed to turn on/off if a system trouble—other than an AC power loss—occurs

Table 2.11 Special Output Functions F1-F4 (2 of 2)

Special Function	Specifies
F2 (AC Trouble)	An output programmed to turn on/off if an AC power loss or a brownout condition occurs
F3 (Security)	An output programmed to turn on/off if a Security input activates
F4 (Supervisory)	An output programmed to turn on/off if a Supervisory input activates

Selecting Special Zones

Select Special Zones by entering the Special Zone letter and number (for example, F0, R0, and so on) from the Special Function Change screen. The following sections show sample screens that display when you select a Special Zone.

F0 (Presignal/PAS) The Presignal screen provides fields for changing the delay time or PAS. For details on Presignal selections, refer to “Presignal and PAS Time” on page 92. From the Special Function Change screen, press the **F** key, then press the **0** key to display the Presignal Function screen.

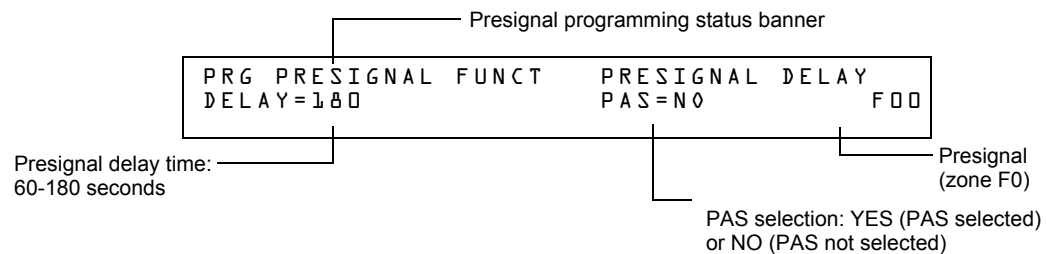

R0-R9 (Releasing Functions) The Releasing Function screen provides fields for changing releasing functions: Delay Timer, Abort Switch, Cross Zone, and Soak Timer. For details on releasing applications, refer to “NFPA Releasing Applications” on page 61.



NOTE: The FCM-1-REL has an inherent two second delay, which must be factored into the DELAY TIME and SOK (soak time) entries.

From the Special Function Change screen, select a function (R0-R9) to display the Releasing Function screen:

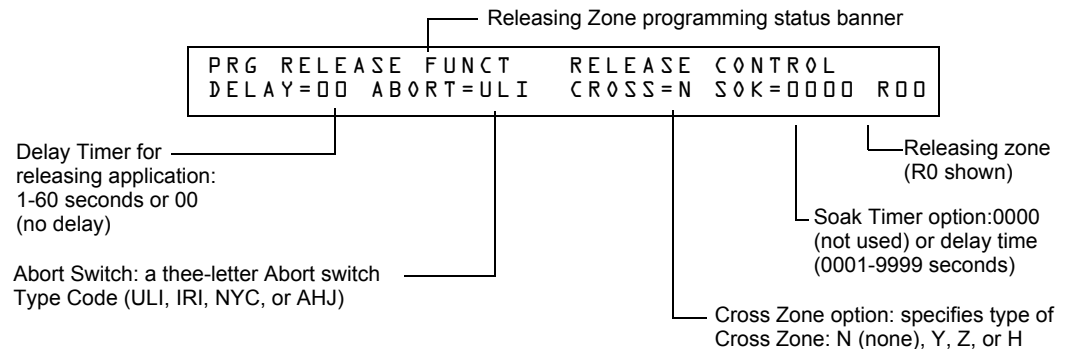

F5-F6 (Time Control Functions) The Time Control screen provides fields for changing the start time, stop time, or days of the week. For details on time selections, refer to “Time Control Zones” on page 93. From the Special Function Change screen, select F5 or F6 to display the Time Control screen:

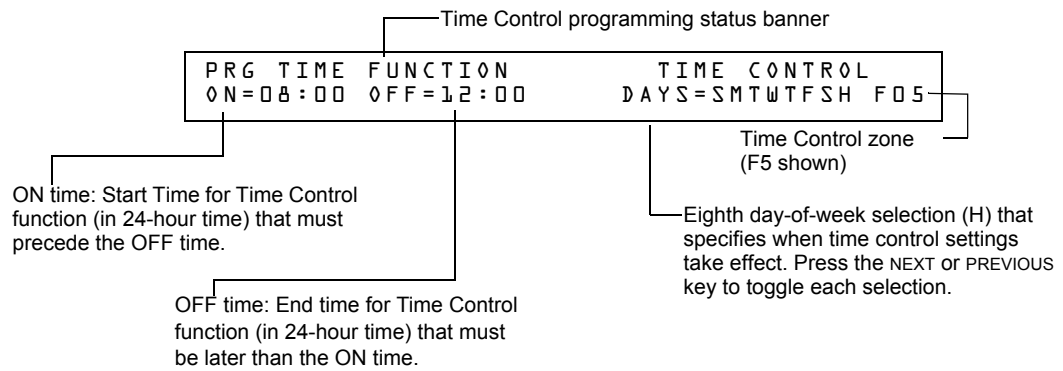

F7 (Holiday) The Holiday screen provides fields for specifying up to nine holiday dates. For details on holiday selections, refer to “Time Control Zones” on page 93. From the Special Function Change screen, press **F7** to display the Holiday screen:

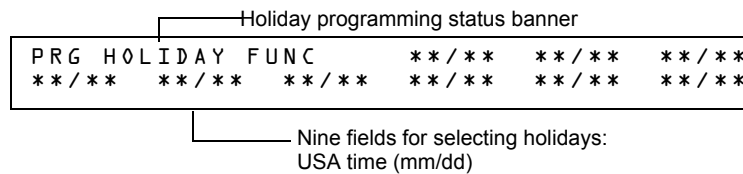

F8 (Coding Function) The Coding Function screen provides fields for specifying one of the following coding functions: March Time, Two-stage, California, Temporal, Two-Stage Canada (3 minutes), Two-Stage Canada (5 minutes), Two-Stage Canada Manual, System Sensor Strobe, Gentex Strobe, and Wheelock Strobe. For details on selecting coding functions, refer to “Coding Functions for NACS” on page 93. From the Special Function Change screen, press **F8** to display the Coding Function screen:

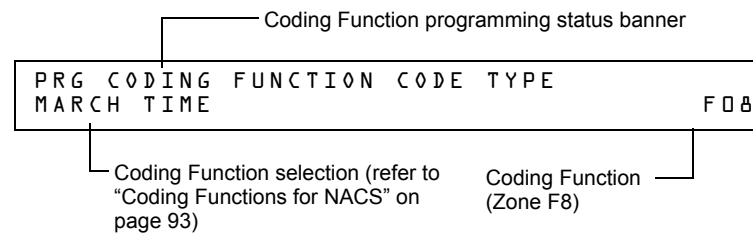

F9 (Pre-Alarm) The Pre-Alarm screen provides fields for programming the Alert or Action Pre-Alarm functions. For details on Pre-Alarm selections, refer to “Pre-Alarm” on page 99. From the Special Function Change screen, press **F9** to display the Pre-Alarm screen:

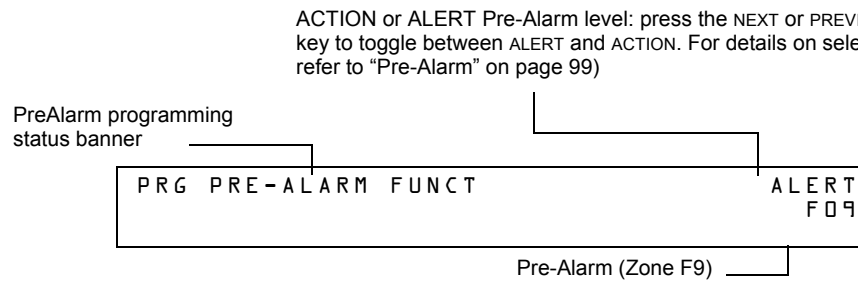

FA (Verification) Turn on when detector in verification mode. This is a fixed point and is not programmable.

FB (Custom drill zone) Turn on if custom drill set to Y and the panel in Drill mode.

FC (CO Alarm) Turn on in the event a CO alarm is present on an FCO-851 detector or monitor module with a CO monitor type code.

FA, FB and FC can map to output point only. It can be mapped to the output device as a CBE using either panel key pad or VeriFire tools. But the custom drill option (Yes or No) is only programmed by VeriFire tools.

FD (MN Alarm) Turn on when an MN Alarm occurs on the fire panel. (Not applicable for FirstCommand applications).

FE (MN Supervisory) Turn on when an MN Supervisory occurs on the fire panel.

FF (MN Trouble) Turn on when an MN Trouble occurs on the fire panel.

2.3.8 Change Global System Functions (7=SYSTEM)



The System option lets you select settings for global system functions that apply to all programmed devices and zones. For instance, selecting an Alarm Verification Timer for 30 seconds means that all initiating devices selected for Alarm Verification use a 30-second timer. From the “Basic Program” screen, press the 7 key to display the “System Function” screen as shown below:

```
SIL INH=000 AUTO=000 VERIFY=30 USA TIME
TERM=N AC_DLY=Y LocT BLINK=01 ST=4 ACS=N
```

Global System Functions

Settings for global system functions:

Table 2.12 Settings for Global Systems Functions (1 of 2)

System Function	Setting	Default
SIL INH (Silence Inhibit Timer)	0 to 300 seconds	000
AUTO (Auto Silence Timer) - After the time delay expires, functions like pressing the SIGNAL SILENCE key, silencing active outputs programmed as silenceable.	000 (none); 600 to 900 seconds	000
VERIFY (Alarm Verification Timer)	0 to 60 seconds*	60

Table 2.12 Settings for Global Systems Functions (2 of 2)

System Function	Setting	Default
USA TIME	USA time (mm/dd/yy) or EUR time (dd/mm/yy) Press the NEXT or PREVIOUS key to change. Note that (European) time changes to 24-hour time format and date format.	USA
TERM - Allows supervision for devices connected to TB11, i.e., FDU-80.	N = no supervision Y = supervision enabled	N
AC_DLY**	AC delay – delays loss of AC reporting for 3 hours. Y=AC delay; N=no AC delay	Y
LocX - One of three operating modes of PC or terminal connected to the control panel through TB12 on the CPU2-640. Note: For a complete list of functions, refer to the <i>NFS2-640 Operations Manual</i> .	LocT -(terminal connected to control panel and located in same room). LocM -(same as LocT but requires password). RemT -(terminal connected through a modem for Read Status only).	LocT
BLINK - Addressable SLC device LED blink.	Select from 00 to 16. (00 = no blink, 01 = blink every poll, 02 = blink every 2nd poll, 03 = blink every 3rd poll up to 16 = blink every 16th poll). Note that this setting affects FlashScan modules only.	01
ST - The NFPA wiring style used for the SLC.	6=Style 6 SLC wiring 4=Style 4 SLC wiring	4
ACS - Use ACS Selection Groups (Refer to "Annunciator Options" on page 33).	N or Y	N
<p>*This value can not exceed 30 seconds for ULC installations. **The onboard trouble relay will activate (TB4 on the NFS2-640 CPU) and TM-4s will report according to this setting. UDACTs and UDACT-2s are notified immediately of AC failure by the panel, regardless of the panel's delay setting. Once the UDACT or UDACT-2 receives notification, it operates according to its own programmed AC Fail Delay reporting schedule.</p> <p>Example: AC Failure occurs at 1:00 p.m. on a panel with an AC_DLY setting of Y (3 hours). The UDACT/UDACT-2 is set for notification after 1 hour. 1:00 p.m. - AC Failure. Panel notifies UDACT/UDACT-2. Panel and UDACT/UDACT-2 timers begin countdown to report time. 2:00 p.m. - UDACT/UDACT-2 reports. 4:00 p.m. - TM-4 reports, TB4 trouble relay activates. The ACPS-610 and ACPS-2406 power supplies must be set to an AC Delay value of 0 (zero) when used with this panel.</p>		

Annunciator Options

NOTE: An ACM-24AT or AEM-24AT LED point must be programmed as a dedicated visual indicator for a mass notification or CO event. This is not required for displayless systems.

Use Annunciator Selection screens to select information that will display on the ACS annunciators. (Table 2.13 on page 34 contains the ACS display selections.) Setting ACS=Y from the “System Function” screen displays the Annunciator Selection 1 screen, address A1-A11. Press enter to display Annunciator Selection 2 screen, address A12 - A19:

ACS Address A1-A11	ACS Selection Group (A-M; 0-9) or *=not selected
<pre> ANNUN SELECTION1 A1=* A2=* A3=* A4=* A5=* A6=* A7=* A8=* A9=* A10=* A11=* </pre>	

ACS Address A12-A19
<pre> ANNUN SELECTION2 A12=* A13=* A14=* A15=* A16=* A17=* A18=* A19=* UDACT=0 </pre>

If UDACT=2: The UDACT is installed with Detector Maintenance Reporting. A24-A31 are pre-programmed to send control panel status to the UDACT. Only the first 100 detectors on Loop 1 and Loop 2 participate in Detector Maintenance Reporting. For pre-programmed point addressing, refer to associated table for Groups P through W on the following pages. UDACT-2 does not support this option.

If UDACT=1: The UDACT or UDACT-2 is installed. Addresses A20-A32 are available to send control panel status to the UDACT (software release #UDACT02.1 or higher) or the UDACT-2

If UDACT=0: No UDACT or UDACT-2 is installed. The control panel displays the Annunciator Selection 3 & 4 screen for addresses A20-A32.

Enter “N” (ACS Selection Group N) for a TM-4 module used for remote station communication.

Enter “O” (ACS Selection Group O) for a TM-4 used as a municipal box trip. This will provide a “Master Box” trouble message at the panel.

Refer to page 41 for further information on Group N and Group O.

ACS Selection Group Example

An example of a screen listing ACS Selection Groups (H, I and M):

ACS Address (A1)	ACS Selection Group (H)
<pre> ANNUN SELECTION1 A1=H A2=I A3=* A4=* A5=B A6=* A7=* A8=* A9=* A10=* A11=* </pre>	

Annunciator selections for addresses A1, A2 and A3 (addresses A4-A11 not selected).

- Annunciators set to Address 1 display the status of detectors 1-64 (Group H) on SLC 1
- Annunciators set to Address 2 display the status of detectors 1-64 (Group I) on SLC 2

Annunciation Points

The control panel's annunciation points are divided into 23 ACS selection groups of 64 points each. The table below contains a list of these groups, what an annunciator displays when a group is selected, and where to locate a definition of the 64 points within the group.

Table 2.13 ACS Selection Groups (1 of 2)

ACS Selection Group	Annunciator Display	Refer to
A	8 System points & Zones 1 - 56	Table 2.14 on page 35
B	Zones 57 - 99, 9 F Zones, 8 R Zones, 4 NACs	Table 2.15 on page 36
C	Loop 1, Modules 1 - 64	Table 2.16 on page 36
D	Loop 2, Modules 1 - 64	Table 2.17 on page 37
E	Loop 1, Modules 65 - 128	Table 2.18 on page 37
F	Loop 2, Modules 65 - 128	Table 2.19 on page 37
G	Loop 1, Modules 129 - 159 (1 unused point) Loop 2, Modules 129 - 159 (1 unused point)	Table 2.20 on page 37
H	Loop 1, Detectors 1 - 64	Table 2.21 on page 38
I	Loop 2, Detectors 1 - 64	Table 2.22 on page 39
J	Loop 1, Detectors 65 - 128	Table 2.23 on page 39
K	Loop 2, Detectors 65 - 128	Table 2.24 on page 39
L	Loop 1, Detectors 129 - 159 (1 unused point) Loop 2, Detectors 129 - 159 (1 unused point)	Table 2.25 on page 40
M	Programmable for use with FireVoice NFV-25/50ZS or FirstCommand	Table 2.26 on page 41
N	8 System Points & Zones 1-56	"ACS Selection Group N" on page 41
O	8 System Points & Zones 1-56	"ACS Selection Group O" on page 41
P*	Loop 1, Modules 65-100 Loop 1, Detectors 1-14 (Each detector occupies 2 points)	Table 2.27 on page 42
Q*	Loop 2, modules 65-100 Loop 2, Detectors 1-14 (Each detector occupies 2 points)	Table 2.28 on page 43
R*	Loop 1, detectors 15-46 (Each detector occupies 2 points)	Table 2.29 on page 44
S*	Loop 2, Detectors 15-46 (Each detector occupies 2 points)	Table 2.30 on page 44
T*	Loop 1 Detectors 47-78 (Each detector occupies 2 points)	Table 2.31 on page 45
U*	Loop 2, Detectors 47-78 (Each detector occupies 2 points)	Table 2.32 on page 45
V*	Loop 1, Detectors 79-100 (Each detector occupies 2 points)	Table 2.33 on page 46
W*	Loop 2, Detectors 79-100 (Each detector occupies 2 points)	Table 2.34 on page 46
*Group only available with UDACT programmed as option 2.		
1	Programmable Annunciator #1	See Note
2	Programmable Annunciator #2	See Note
3	Programmable Annunciator #3	See Note

Table 2.13 ACS Selection Groups (2 of 2)

ACS Selection Group	Annunciator Display	Refer to
4	Programmable Annunciator #4	See Note
5	Programmable Annunciator #5	See Note
6	Programmable Annunciator #6	See Note
7	Programmable Annunciator #7	See Note
8	Programmable Annunciator #8	See Note
9	Programmable Annunciator #9	See Note
0	Programmable Annunciator #10	See Note



NOTE: Refer to the VeriFire™ Tools programming utility for programming these annunciators.

ACS Selection Group A:

Table 2.14 ACS Group A

Point	Type	Red LED	Yellow LED	Switch Function*
1	Input	System Alarm	System Trouble	Acknowledge
2	Output	Not Used	Signal Silenced	Alarm Silence
3	Output	Not Used	Program Mode	System Reset
4	Output	Not Used	Supervisory	Drill
5	Output	NAC #1 Active	NAC Trouble	Control NAC #1
6	Input	Security	P/A Maint. Alert	Not Used
7	Input	Not Used	Low Battery	Not Used
8	Input	Not Used	AC Fail	Not Used
9	Input	Zone 1 Active	Zone 1 Trouble	Not Used
10	Input	Zone 2 Active	Zone 2 Trouble	Not Used
11	Input	Zone 3 Active	Zone 3 Trouble	Not Used
to		to (see note)	to (see note)	
64	Input	Zone 56 Active	Zone 56 Trouble	Not Used

* Pressing the switch button when the Switch Function is "Not Used" will cause the associated LED to stop blinking. This is a local acknowledgement at the annunciator only; no message is sent to the panel.



NOTE: Point number to Zone number relationship is sequential. To determine Point to Zone relationship subtract 8 from Point number to arrive at Zone number.

ACS Selection Group B:**Table 2.15 ACS Group B**

Point	Type	Red LED	Yellow LED	Switch Function*
1	Input	Zone 57 Active	Zone 57 Trouble	Not Used
2	Input	Zone 58 Active	Zone 58 Trouble	Not Used
3	Input	Zone 59 Active	Zone 59 Trouble	Not Used
to		to (see note 1)	to (see note 1)	
43	Input	Zone 99 Active	Zone 99 Trouble	Not Used
44	Output	Zone F1 Active	Zone F1 Trouble	Not Used
45	Output	Zone F2 Active	Zone F2 Trouble	Not Used
to		to (see note 2)	to (see note 2)	
52	Output	Zone F9 Active	Zone F9 Trouble	Not Used
53	Release Ckt #0	Zone R0 Active	Zone R0 Trouble	Not Used
54	Release Ckt #1	Zone R1 Active	Zone R1 Trouble	Not Used
to	to	to (see note 2)	to (see note 2)	
60	Release Ckt #7	Zone R7 Active	Zone R7 Trouble	Not Used
61	NAC Output	NAC B01 Active	NAC B01 Trouble	Controls NAC B01
62	NAC Output	NAC B02 Active	NAC B02 Trouble	Controls NAC B02
63	NAC Output	NAC B03 Active	NAC B03 Trouble	Controls NAC B03
64	NAC Output	NAC B04 Active	NAC B04 Trouble	Controls NAC B04
* Pressing the switch button when the Switch Function is "Not Used" will cause the associated LED to stop blinking. This is a local acknowledgement at the annunciator only: no message is sent to the panel.				

**NOTE:**

1. Point number to Zone number relationship is sequential. To determine Point to Zone relationship, add 56 to Point number to arrive at Zone number.
2. Point number to Zone number relationship is sequential; therefore, point 48 is zone F5 and point 57 is zone R4.

ACS Selection Group C (SLC #1, Modules 1-64):**Table 2.16 ACS Group C**

Point	Type	Red LED	Yellow LED	Switch Function
1	Input or Output	Module 001 Active	Module 001 Trouble	Controls Output Module
2	Input or Output	Module 002 Active	Module 002 Trouble	Controls Output Module
3	Input or Output	Module 003 Active	Module 003 Trouble	Controls Output Module
to		to (see note)	to (see note)	
64	Input or Output	Module 064 Active	Module 064 Trouble	Controls Output Module



NOTE: Point number to Module number relationship is sequential; therefore, point 48 is Module 048.

ACS Selection Group D (SLC #2, Modules 1-64):**Table 2.17 ACS Group D**

Point	Type	Red LED	Yellow LED	Switch Function
1	Input or Output	Module 001 Active	Module 001 Trouble	Controls Output Module
2	Input or Output	Module 002 Active	Module 002 Trouble	Controls Output Module
3	Input or Output	Module 003 Active	Module 003 Trouble	Controls Output Module
to		to (see note)	to (see note)	
64	Input or Output	Module 064 Active	Module 064 Trouble	Controls Output Module



NOTE: Point number to Module number relationship is sequential; therefore, point 48 is Module 048.

ACS Selection Group E (SLC #1, Modules 65-128):**Table 2.18 ACS Group E**

Point	Type	Red LED	Yellow LED	Switch Function
1	Input or Output	Module 065 Active	Module 065 Trouble	Controls Output Module
2	Input or Output	Module 066 Active	Module 066 Trouble	Controls Output Module
3	Input or Output	Module 067 Active	Module 067 Trouble	Controls Output Module
to		to (see note)	to (see note)	
64	Input or Output	Module 128 Active	Module 128 Trouble	Controls Output Module



NOTE: Point number to Module number relationship is sequential. To determine Point to Module relationship add 64 to Point number to arrive at Module number.

ACS Selection Group F (SLC #2, Modules 65-128):**Table 2.19 ACS Group F**

Point	Type	Red LED	Yellow LED	Switch Function
1	Input or Output	Module 065 Active	Module 065 Trouble	Controls Output Module
2	Input or Output	Module 066 Active	Module 066 Trouble	Controls Output Module
3	Input or Output	Module 067 Active	Module 067 Trouble	Controls Output Module
to		to (see note)	to (see note)	
64	Input or Output	Module 128 Active	Module 128 Trouble	Controls Output Module



NOTE: Point number to Module number relationship is sequential. To determine Point to Module relationship add 64 to Point number to arrive at Module number.

ACS Selection Group G (SLC #1 and #2, Modules 129-159):**Table 2.20 ACS Group G (1 of 2)**

Point	Type	Red LED	Yellow LED	Switch Function
1	Output	SLC 1, Module 129 Active	SLC 1, Module 129 Trouble	Controls SLC 1, Module 129
2	Output	SLC 1, Module 130 Active	SLC 1, Module 130 Trouble	Controls SLC 1, Module 130

Table 2.20 ACS Group G (2 of 2)

Point	Type	Red LED	Yellow LED	Switch Function
3	Output	SLC 1, Module 131 Active	SLC 1, Module 131 Trouble	Controls SLC 1, Module 131
to		to (see note 1)	to (see note 1)	
31	Output	SLC 1, Module 159 Active	SLC 1, Module 159 Trouble	Controls SLC 1, Module 159
32	Not Used			
33	Output	SLC 2, Module 129 Active	SLC 2, Module 129 Trouble	Controls SLC 2, Module 129
34	Output	SLC 2, Module 130 Active	SLC 2, Module 130 Trouble	Controls SLC 2, Module 130
35	Output	SLC 2, Module 131 Active	SLC 2, Module 131 Trouble	Controls SLC 2, Module 131
		to (see note 2)	to (see note 2)	
63	Output	SLC 2, Module 159 Active	SLC 2, Module 159 Trouble	Controls SLC 2, Module 159
64	Not Used			

**NOTE:**

1. Point number to Module number relationship is sequential. To determine Point to Module relationship add 128 to Point number to arrive at Module number.
2. Point number to Module number relationship is sequential. To determine Point to Module relationship add 96 to Point number to arrive at Module number.

ACS Selection Group H (SLC #1, Detectors 1-64):

Table 2.21 ACS Group H

Point	Type	Red LED	Yellow LED	Switch Function*
1	Input	Detector 001 Alarm	Detector 001 Trouble	Not Used
2	Input	Detector 002 Alarm	Detector 002 Trouble	Not Used
3	Input	Detector 003 Alarm	Detector 003 Trouble	Not Used
to		to (see note)	to (see note)	
64	Input	Detector 064 Alarm	Detector 064 Trouble	Not Used

* Pressing the switch button when the Switch Function is "Not Used" will cause the associated LED to stop blinking. This is a local acknowledgement at the annunciator only; no message is sent to the panel.



NOTE: Point number to Detector number relationship is sequential; therefore, point 48 is Detector 048.

ACS Selection Group I (SLC #2, Detectors 1-64):**Table 2.22 ACS Group I**

Point	Type	Red LED	Yellow LED	Switch Function*
1	Input	Detector 001 Alarm	Detector 001 Trouble	Not Used
2	Input	Detector 002 Alarm	Detector 002 Trouble	Not Used
3	Input	Detector 003 Alarm	Detector 003 Trouble	Not Used
to		to (see note)	to (see note)	
64	Input	Detector 064 Alarm	Detector 064 Trouble	Not Used

* Pressing the switch button when the Switch Function is "Not Used" will cause the associated LED to stop blinking. This is a local acknowledgement at the annunciator only: no message is sent to the panel.



NOTE: Point number to Detector number relationship is sequential; therefore, point 48 is Detector 048.

ACS Selection Group J (SLC #1, Detectors 65-128):**Table 2.23 ACS Group J**

Point	Type	Red LED	Yellow LED	Switch Function*
1	Input	Detector 065 Alarm	Detector 065 Trouble	Not Used
2	Input	Detector 066 Alarm	Detector 066 Trouble	Not Used
3	Input	Detector 067 Alarm	Detector 067 Trouble	Not Used
to		to (see note)	to (see note)	
64	Input	Detector 128 Alarm	Detector 128 Trouble	Not Used

* Pressing the switch button when the Switch Function is "Not Used" will cause the associated LED to stop blinking. This is a local acknowledgement at the annunciator only: no message is sent to the panel.



NOTE: Point number to Detector number relationship is sequential. To determine Point to Detector relationship add 64 to Point number to arrive at Detector number.

ACS Selection Group K (SLC #2, Detectors 65-128):**Table 2.24 ACS Group K**

Point	Type	Red LED	Yellow LED	Switch Function*
1	Input	Detector 065 Alarm	Detector 065 Trouble	Not Used
2	Input	Detector 066 Alarm	Detector 066 Trouble	Not Used
3	Input	Detector 067 Alarm	Detector 067 Trouble	Not Used
to		to (see note)	to (see note)	
64	Input	Detector 128 Alarm	Detector 128 Trouble	Not Used

* Pressing the switch button when the Switch Function is "Not Used" will cause the associated LED to stop blinking. This is a local acknowledgement at the annunciator only: no message is sent to the panel.



NOTE: Point number to Detector number relationship is sequential. To determine Point to Detector relationship add 64 to Point number to arrive at Detector number

ACS Selection Group L (SLC #1, Detectors 129-159, and SLC #2, Detectors 129-159):

Table 2.25 ACS Group L

Point	Type	Red LED	Yellow LED	Switch Function*
1	Input	SLC 1, Detector 129 Alarm	SLC 1, Detector 129 Trouble	Not Used
2	Input	SLC 1, Detector 130 Alarm	SLC 1, Detector 130 Trouble	Not Used
3	Input	SLC 1, Detector 131 Alarm	SLC 1, Detector 131 Trouble	Not Used
to		to (see note 1)	to (see note 1)	
31	Input	SLC 1, Detector 159 Alarm	SLC 1, Detector 159 Trouble	Not Used
32	Not Used			
33	Input	SLC 2, Detector 129 Alarm	SLC 2, Detector 129 Trouble	Not Used
34	Input	SLC 2, Detector 130 Alarm	SLC 2, Detector 130 Trouble	Not Used
35	Input	SLC 2, Detector 131 Alarm	SLC 2, Detector 131 Trouble	Not Used
		to (see note 2)	to (see note 2)	
63	Input	SLC 2, Detector 159 Alarm	SLC 2, Detector 159 Trouble	Not Used
64	Not Used			

* Pressing the switch button when the Switch Function is "Not Used" will cause the associated LED to stop blinking. This is a local acknowledgement at the annunciator only; no message is sent to the panel.



NOTE:

1. Point number to Detector number relationship is sequential. To determine Point to Detector relationship add 128 to Point number to arrive at Detector number.
2. Point number to Detector number relationship is sequential. To determine Point to Detector relationship add 96 to Point number to arrive at Detector number.

ACS Selection Group M

FirstCommand NFC-50/100 and FireVoice (NFV-25/50ZS) are single channel and can play one message. Message priority is determined by the message number: lower-numbered messages have the higher priorities (that is, Message 2 has a higher priority than Message 3). Message 0 (OFF) has the lowest priority.

To use ACS for controlling the FirstCommand and FireVoice, install by programming Annunciator A1 as Group M through panel or VeriFire Tools programming. Refer to the First Command or FireVoice manual to properly configure the FACP.

■ VeriFire Tools Programming

Annunciator programming must be performed as follows:

- Program Annunciator Address 1 as Group M. (Refer to Table 2.26 for point definitions.)
- Assign ACS points in user Map 1.

- Map the panel zones to the desired annunciator point. Refer to the FirstCommand or FireVoice NFV-25/50ZS manual for more information, including dipswitch settings.

Table 2.26 Point Definitions for Group M

Annunciator Point	Type
1 - 9	Unused
10	Message 0 (No Message/Message Off)
11	Message 1
12	Message 2
13	Message 3
14	Message 4
15	Message 5
16 - 39	FFT Circuits
40	All-Call
41 - 64	Speaker Circuits 1 - 24

■ Panel Programming

If VeriFire Tools is not used and Group M is programmed at the panel, Zone 00 (general alarm) will be mapped to A1p11 and A1p40. A general alarm will play message 1 and activate an all-call on the FirstCommand or FireVoice. VeriFire Tools must be used for speaker circuit and message control.

ACS Selection Group N

This group is the same as Group A (See Table 2.14 on page 35), with the following exceptions:

- It should be selected only for TM-4s used for remote station communication.
- Selection Group N follows the alarm relay for annunciation (Selection Group A annunciates immediately).
- The yellow LED of annunciator point 2 is for Alarm Silence only (in Selection Group A it is for Signal Silenced).

ACS Selection Group O

This group is the same as Group A (See Table 2.14 on page 35), with the following exceptions:

- It should be selected for only for TM-4s used as Fire Municipal Box Trip outputs.
- Selection Group O provides a “Master Box” trouble displayed at the panel.
- Selection Group O follows the alarm relay for annunciation (Selection Group A annunciates immediately).

The yellow LED of annunciator point 2 is for Alarm Silence only (in Selection Group A it is for Signal Silenced).

ACS Selection Group P (SLC #1, Modules 65-100 and Detectors 1-14):**Table 2.27 ACS Group P (see note 3)**

Point	Type	Red LED	Yellow LED	Switch Function*
1	Input	SLC 1, Module 65 Alarm	SLC 1, Module 65 Trouble	Not Used
2	Input	SLC 1, Module 66 Alarm	SLC 1, Module 66 Trouble	Not Used
3	Input	SLC 1, Module 67 Alarm	SLC 1, Module 67 Trouble	Not Used
to		to (see note 1)	to (see note 1)	
36	Input	SLC 1, Module 100 Alarm	SLC 1, Module 100 Trouble	Not Used
37	Input	SLC 1, Detector 1 Alarm	SLC 1, Detector 1 Trouble	Not Used
38	Input	SLC 1, Detector 1 Trouble Maintenance Urgent	SLC 1, Detector 1 Trouble Maintenance Alert	Not Used
39	Input	SLC 1, Detector 2 Alarm	SLC 1, Detector 2 Trouble	Not Used
40	Input	SLC 1, Detector 2 Trouble Maintenance Urgent	SLC 1, Detector 2 Trouble Maintenance Alert	Not Used
		to (see note 2)	to (see note 2)	
63	Input	SLC 1, Detector 14 Alarm	SLC 1, Detector 14 Trouble	Not Used
64	Input	SLC 1, Detector 14 Trouble Maintenance Urgent	SLC 1, Detector 14 Trouble Maintenance Alert	Not Used
* Pressing the switch button when the Switch Function is "Not Used" will cause the associated LED to stop blinking. This is a local acknowledgement at the annunciator only: no message is sent to the panel.				

**NOTE:**

1. Point number to Module number relationship is sequential. To determine Point to Module relationship add 64 to Point number to arrive at Module number.
2. Point number to Detector number relationship is sequential in groups of 2. Since each detector occupies 2 points, to determine the Point to Detector relationship, count by 2 starting from point 37.
3. This group is only available when UDACT setting is programmed as option 2 and will automatically be assigned to ACS address 24.

ACS Selection Group Q (SLC #2, Modules 65-100 and Detectors 1-14):**Table 2.28 ACS Group Q (see note 3)**

Point	Type	Red LED	Yellow LED	Switch Function*
1	Input	SLC 2, Module 65 Alarm	SLC 2, Module 65 Trouble	Not Used
2	Input	SLC 2, Module 66 Alarm	SLC 2, Module 66 Trouble	Not Used
3	Input	SLC 2, Module 67 Alarm	SLC 2, Module 67 Trouble	Not Used
to		to (see note 1)	to (see note 1)	
36	Input	SLC 2, Module 100 Alarm	SLC 2, Module 100 Trouble	Not Used
37	Input	SLC 2, Detector 1 Alarm	SLC 2, Detector 1 Trouble	Not Used
38	Input	SLC 2, Detector 1 Trouble Maintenance Urgent	SLC 2, Detector 1 Trouble Maintenance Alert	Not Used
39	Input	SLC 2, Detector 2 Alarm	SLC 2, Detector 2 Trouble	Not Used
40	Input	SLC 2, Detector 2 Trouble Maintenance Urgent	SLC 2, Detector 2 Trouble Maintenance Alert	Not Used
		to (see note 2)	to (see note 2)	
63	Input	SLC 2, Detector 14 Alarm	SLC 2, Detector 14 Trouble	Not Used
64	Input	SLC 2, Detector 14 Trouble Maintenance Urgent	SLC 2, Detector 14 Trouble Maintenance Alert	Not Used
* Pressing the switch button when the Switch Function is "Not Used" will cause the associated LED to stop blinking. This is a local acknowledgement at the annunciator only: no message is sent to the panel.				

**NOTE:**

1. Point number to Module number relationship is sequential. To determine Point to Module relationship add 64 to Point number to arrive at Module number.
2. Point number to Detector number relationship is sequential in groups of 2. Since each detector occupies 2 points, to determine the Point to Detector relationship, count by 2 starting from point 37.
3. This group is only available when UDACT setting is programmed as option 2 and will automatically be assigned to ACS address 25.

ACS Selection Group R (SLC #1, Detectors 15-46):**Table 2.29 ACS Group R**

Point	Type	Red LED	Yellow LED	Switch Function*
1	Input	Detector 015 Alarm	Detector 015 Trouble	Not Used
2	Input	Detector 015 Trouble Maintenance Urgent	Detector 015 Trouble Maintenance Alert	Not Used
3	Input	Detector 016 Alarm	Detector 016 Trouble	Not Used
4	Input	Detector 016 Trouble Maintenance Urgent	Detector 016 Trouble Maintenance Alert	Not Used
to		to (see note 1)	to (see note 1)	
63	Input	Detector 046 Alarm	Detector 046 Trouble	Not Used
64	Input	Detector 046 trouble Maintenance Urgent	Detector 046 Trouble Maintenance Alert	Not Used

* Pressing the switch button when the Switch Function is "Not Used" will cause the associated LED to stop blinking. This is a local acknowledgement at the annunciator only: no message is sent to the panel.

**NOTE:**

1. Point number to Detector number relationship is sequential in groups of 2. Since each detector occupies 2 points, to determine the Point to Detector relationship, start with detector 15 and count by 2 starting from point 1.
2. This group is only available when UDACT setting is programmed as option 2 and will automatically be assigned to ACS address 26.

ACS Selection Group S (SLC #2, Detectors 15-46):**Table 2.30 ACS Group S**

Point	Type	Red LED	Yellow LED	Switch Function*
1	Input	Detector 015 Alarm	Detector 015 Trouble	Not Used
2	Input	Detector 015 Trouble Maintenance Urgent	Detector 015 Trouble Maintenance Alert	Not Used
3	Input	Detector 016 Alarm	Detector 016 Trouble	Not Used
4	Input	Detector 016 Trouble Maintenance Urgent	Detector 016 Trouble Maintenance Alert	Not Used
to		to (see note 1)	to (see note 1)	
63	Input	Detector 046 Alarm	Detector 046 Trouble	Not Used
64	Input	Detector 046 Trouble Maintenance Urgent	Detector 046 Trouble Maintenance Alert	Not Used

* Pressing the switch button when the Switch Function is "Not Used" will cause the associated LED to stop blinking. This is a local acknowledgement at the annunciator only: no message is sent to the panel.

**NOTE:**

1. Point number to Detector number relationship is sequential in groups of 2. Since each detector occupies 2 points, to determine the Point to Detector relationship, start with detector 15 and count by 2 starting from point 1.
2. This group is only available when UDACT setting is programmed as option 2 and will automatically be assigned to ACS address 27.

ACS Selection Group T (SLC #1, Detectors 47-78):**Table 2.31 ACS Group T**

Point	Type	Red LED	Yellow LED	Switch Function*
1	Input	Detector 047 Alarm	Detector 047 Trouble	Not Used
2	Input	Detector 047 trouble Maintenance Urgent	Detector 047 Trouble Maintenance Alert	Not Used
3	Input	Detector 048 Alarm	Detector 048 Trouble	Not Used
4	Input	Detector 048 Trouble Maintenance Urgent	Detector 048 Trouble Maintenance Alert	Not Used
to		to (see note 1)	to (see note 1)	
63	Input	Detector 078 Alarm	Detector 078 Trouble	Not Used
64	Input	Detector 078 Trouble Maintenance Urgent	Detector 078 Trouble Maintenance Alert	Not Used

* Pressing the switch button when the Switch Function is "Not Used" will cause the associated LED to stop blinking. This is a local acknowledgement at the annunciator only: no message is sent to the panel.

**NOTE:**

1. Point number to Detector number relationship is sequential in groups of 2. Since each detector occupies 2 points, to determine the Point to Detector relationship, start with detector 47 and count by 2 starting from point 1.
2. This group is only available when UDACT setting is programmed as option 2 and will automatically be assigned to ACS address 28.

ACS Selection Group U (SLC #2, Detectors 47-78):**Table 2.32 ACS Group U**

Point	Type	Red LED	Yellow LED	Switch Function*
1	Input	Detector 047 Alarm	Detector 047 Trouble	Not Used
2	Input	Detector 047 Trouble Maintenance Urgent	Detector 047 Trouble Maintenance Alert	Not Used
3	Input	Detector 048 Alarm	Detector 048 Trouble	Not Used
4	Input	Detector 048 Trouble Maintenance Urgent	Detector 048 Trouble Maintenance Alert	Not Used
to		to (see note 1)	to (see note 1)	
63	Input	Detector 078 Alarm	Detector 078 Trouble	Not Used
64	Input	Detector 078 Trouble Maintenance Urgent	Detector 078 Trouble Maintenance Alert	Not Used

* Pressing the switch button when the Switch Function is "Not Used" will cause the associated LED to stop blinking. This is a local acknowledgement at the annunciator only: no message is sent to the panel.

**NOTE:**

1. Point number to Detector number relationship is sequential in groups of 2. Since each detector occupies 2 points, to determine the Point to Detector relationship, start with detector 47 and count by 2 starting from point 1.
2. This group is only available when UDACT setting is programmed as option 2 and will automatically be assigned to ACS address 29.

ACS Selection Group V (SLC #1, Detectors 79-100):**Table 2.33 ACS Group V**

Point	Type	Red LED	Yellow LED	Switch Function*
1	Input	Detector 079 Alarm	Detector 079 Trouble	Not Used
2	Input	Detector 079 Trouble Maintenance Urgent	Detector 079 Trouble Maintenance Alert	Not Used
3	Input	Detector 080 Alarm	Detector 080 Trouble	Not Used
4	Input	Detector 080 Trouble Maintenance Urgent	Detector 080 Trouble Maintenance Alert	Not Used
to		to (see note 1)	to (see note 1)	
63	Input	Detector 100 Alarm	Detector 100 Trouble	Not Used
64	Input	Detector 100 Trouble Maintenance Urgent	Detector 100 Trouble Maintenance Alert	Not Used

* Pressing the switch button when the Switch Function is "Not Used" will cause the associated LED to stop blinking. This is a local acknowledgement at the annunciator only: no message is sent to the panel.

**NOTE:**

1. Point number to Detector number relationship is sequential in groups of 2. Since each detector occupies 2 points, to determine the Point to Detector relationship, start with detector 79 and count by 2 starting from point 1.
2. This group is only available when UDACT setting is programmed as option 2 and will automatically be assigned to ACS address 30.

ACS Selection Group W (SLC #2, Detectors 79-100):**Table 2.34 ACS Group W**



Point	Type	Red LED	Yellow LED	Switch Function*
1	Input	Detector 079 Alarm	Detector 079 Trouble	Not Used
2	Input	Detector 079 Trouble Maintenance Urgent	Detector 079 Trouble Maintenance Alert	Not Used
3	Input	Detector 080 Alarm	Detector 080 Trouble	Not Used
4	Input	Detector 080 Trouble Maintenance Urgent	Detector 080 Trouble Maintenance Alert	Not Used
to		to (see note 1)	to (see note 1)	
63	Input	Detector 100 Alarm	Detector 100 Trouble	Not Used
64	Input	Detector 100 Trouble Maintenance Urgent	Detector 100 Trouble Maintenance Alert	Not Used

* Pressing the switch button when the Switch Function is "Not Used" will cause the associated LED to stop blinking. This is a local acknowledgement at the annunciator only: no message is sent to the panel.

**NOTE:**

1. Point number to Detector number relationship is sequential in groups of 2. Since each detector occupies 2 points, to determine the Point to Detector relationship, start with detector 79 and count by 2 starting from point 1.
2. This group is only available when UDACT setting is programmed as option 2 and will automatically be assigned to ACS address 31.

2.3.9 How to Check the Program for Errors (8=CHECK PRG)

 
 Program Change
 Password

When finished programming, you can use the Check option to search the program entries for possible errors. From the “Basic Program” screen, press the **8** key. The Check option searches the program for the following conditions that can cause errors:

- Output points mapped to a zone without a mapped input
- A zone with mapped input points without mapped output points (including Z00 outputs)
- Releasing zone inputs (R0-R9) with no RELEASE CKT outputs mapped to them; or RELEASE CKT outputs with no R0-R9 inputs mapped to them
- R0-R9 inputs not mapped to MAN. RELEASE.

For more information on Releasing Zones, refer to “Releasing Applications” on page 60.

If the Check option detects multiple devices that fail the check, press the PREVIOUS or NEXT key to step through the devices. If the Check option displays errors, return to Point Programming (“Modify or Delete a Point (2=point)” on page 19) and correct the errors. The figure below shows a sample display of program screen that appears after a successful program check:

```

PROGRAM CHECK OK.
RE-TEST PANEL NOW      08:34A 041508 Tue
  
```

2.4 The Network Program

 
 Program Change
 Password

From the “Program Change Selection” screen, press the **2** key to display the “Network” screen, which displays as follows:

```

THRESHOLD CH.A:H, THRESHOLD CH.B:H,
NODE: .000, STYLE?:N, <ENTER>
  
```

THRESHOLD CH.A: - Enter H or L, for high or low threshold setting for channel A on the NCM module.

THRESHOLD CH.B: - Enter H or L, for high or low threshold setting for channel B on the NCM module.

NODE: - Enter the panel’s network node number. The valid network node number range is 1-103. The number will be entered after the decimal point; the spaces before the decimal point are for future use.

STYLE7: - Enter N for network style determination (either Style 4 or Style 7) through autoprogramming. Enter Y to force a Style 7 designation for network wiring.



NOTE: If network Style 7 wiring is determined by autoprogramming, a change in the wiring (for example, a break in the network wiring) would cause the system to reassess the network wiring style as 4. If network Style 7 wiring is forced, a break in the wiring will create a trouble message.

To select network options, follow these steps:

1. Using the arrow keys, move the blinking cursor to a selection.
2. Press the NEXT or PREVIOUS key to select **H** or **L** (Threshold Ch. A, Threshold Ch. B), a three-digit number (Node), or **Y** or **N** (Style 7).

When finished making selections, press the ESC key three times to return the control panel to normal operation.

When programming is complete, the panel must be reset to register the programming.

2.5 The Utility Program

There are five options available in the Utility Program. Enter the program and select an option as described below.



From the “Program Change Selection” screen, press the **3** key to display the “Utility Program” screen as shown below:

Program Change
Password



```
REGION=0    TBL.REMIND=2  ALA.SCROLL=N
LOCAL CONTROL=0  IP-ACCESS=0  DCC-mode:Y
```

Descriptions of the five options on the Utility Program screen:

Table 2.35 Utility Program Options (1 of 2)

Utility Option	Description
REGION	0 = No special region setting (default) 1 = China
TBL.REMIND TBL Reminder* *Use of a setting other than “2” requires AHJ approval.	This option provides trouble resound selections to meet the requirements of NFPA 72-2002, which you can select as follows: <ul style="list-style-type: none"> • Select * if you don’t want a trouble reminder • Select 1 to sound a short trouble reminder tone every minute • Select 2 to resound a trouble tone every 24 hours at 11:00 AM, and to send a reminder every sixty seconds for acknowledged events. • Select 3 to display a detector while in the alarm verification mode and no trouble reminder • Select 4 for once a minute trouble reminder with alarm verification display • Select 5 for trouble reminder resound every 24 hours at 11:00 AM with alarm verification display, and to send a reminder every sixty seconds for acknowledged troubles
ALA.SCROLL Alarm Scroll* *Setting this field to “Y” requires AHJ approval.	This option allows the programmer to select how alarms are displayed. <ul style="list-style-type: none"> • Select Y if you want each alarm displayed for approximately two seconds, and to acknowledge all alarms with a single acknowledgement. (default) • Select N if you want only the first alarm and the alarm count displayed, and to acknowledge each alarm singly, point by point.
LOCAL CONTROL	This option allows the programmer to disable local control of the ACKNOWLEDGE/SCROLL DISPLAY key, SIGNAL SILENCE key, DRILL key and SYSTEM RESET key. Select local control as follows: <ul style="list-style-type: none"> • Select 0 to disable local control • Select 1 to enable local control (default) • Select 2 to enable partial local control. This setting allows control of the ACKNOWLEDGE and SYSTEM RESET keys only (required in Chicago.) Note that if the panel is to be controlled exclusively by a Display and Control Center (DCC), Local Control should be disabled.

Table 2.35 Utility Program Options (2 of 2)

Utility Option	Description
IP ACCESS	<p>Note: Use of this option is subject to local AHJ approval.</p> <p>This option allows the programmer to choose one of three options for Wide Area Network (WAN) communication. Acceptance of commands, downloads and programming from over the WAN can be enabled, disabled or timed.</p> <p>Select IP ACCESS as follows:</p> <ul style="list-style-type: none"> • Select 0 to disable IP access • Select 1 to enable IP access • Select 2 to enable IP access for two hours. <p>Note that enabling IP ACCESS allows downloads over a local area network (LAN) or the internet (Wide Area Network - WAN) using VeriFire Tools through a Noti•Fire•Net(NFN) Web Server (NWS), or a wide-area enabled NCS through a PC version of NFN Gateway. Always verify system operation after programming changes are made in this manner.</p>
DCC Mode	<p>This option allows the programmer to select whether this panel will participate in DCC (Display and Control Center) functions. Select Y for participation, N for no participation.</p> <p>NOTE: For Mass Notification applications, DCC participation should be disabled.</p>

To select utility options, follow these steps:

1. Using the arrow keys, move the blinking cursor to a selection.
2. Press the NEXT or PREVIOUS key to select
 - Local Control
 - *, 1, 2, 3, 4, 5 (TBL Reminder)
 - 0, 1, or 2 (IP ACCESS)
 - DCC Mode
3. When finished making selections, press the ESC key three times to return the control panel to normal operation.

2.6 FlashScan Poll



From the “Program Change Selection” screen, press the **4** key to access the “FlashScan Poll” selection screen as shown below:

Program Change
Password



FLASHSCAN	L1DET	L1MOD	L2DET	L2MOD
	N	N	N	N

This menu allows the selection of CLIP (Classic Loop Interface Protocol) or FlashScan detectors and modules for each loop. Once this screen is accessed, the cursor will be positioned underneath the Loop #1 Detector selection, blinking the currently selected protocol type. The default selections are shown in the above figure. This indicates that both Loop #1 and Loop #2 detectors and modules are selected to use CLIP devices. If FlashScan devices are to be employed, change the blinking cursor by pressing the **Y** key or toggle it by using the PREVIOUS or NEXT key. After the selections have been made to the detectors and modules of both loops, press the ENTER key, at which time the panel will reset.

Most FlashScan devices can be programmed to run in either CLIP or FlashScan mode. Observe one of the following three options when using FlashScan devices:

- Option 1** Program all modules and detectors on an SLC as FlashScan.
(In the “FlashScan Poll” screen, enter Y for DET and Y for MOD. It is possible to have up to 159 FlashScan modules and 159 FlashScan detectors on this SLC.)

- Option 2** Program all modules and detectors on an SLC as CLIP.
(In the “FlashScan Poll” screen, enter N for DET and N for MOD. It is possible to have up to 99 CLIP modules and 99 CLIP detectors on this SLC.)

**CAUTION:**

Do not program more than 99 CLIP addresses, as this will compromise the response time of the panel to display off-normal events.

- Option 3** Program all detectors as CLIP and all modules as FlashScan on an SLC.
(In the “FlashScan Poll” screen, enter N for DET and Y for MOD. It is possible to have up to 99 CLIP detectors and 159 FlashScan modules on this SLC.)

**CAUTION:**

Do not program modules as CLIP and detectors as FlashScan on the same SLC. This combination is not an option: Y for DET, N for MOD in the “FlashScan Poll” screen.



NOTE: Autoprogramming following a Clear Program command will cause the panel to determine the FlashScan capability of each loop based on whether all devices on a loop are FlashScan or not. It will set the loop settings to FlashScan if necessary.

Refer to the SLC manual for available devices.

2.7 Setting the Baud Rate of Serial Ports

2.7.1 Printer Serial Port



The default baud rate of the EIA-232 Printer connection (serial printer port) is 9600. To change baud rate to 2400 or 4800, follow these steps:

- From the “SYSTEM NORMAL” screen, press the ENTER key to display the Program Entry screen, as shown below:

```
1=PROGRAMMING      2=READ STATUS ENTRY
(ESCAPE TO ABORT)
```

- Press the **1** key. The control panel displays the Enter Password screen, as shown below:

```
ENTER PROG OR STAT PASSWORD, THEN ENTER.
_ (ESCAPE TO ABORT)
```

- Enter **2400B** and press . The five asterisks that appear when you type in the baud rate will disappear when you press .
- Press  twice to return to the “SYSTEM NORMAL” screen.
- To switch from 2400 baud to 4800 or 9600 baud repeat steps 1, 2, and 3 entering **9600B** or **4800B**.

2.7.2 CRT Serial Port

The default setting for the serial EIA-232 CRT port is “disabled”. To enable the EIA-232 CRT port at 9600 baud, follow the steps below.





NOTE: The serial EIA-232 CRT port can only be enabled in standalone (non-networked) applications. The only baud rate supported is 9600.

1. From the SYSTEM NORMAL screen, press the ENTER key to display the Program Entry screen, as shown below:

```
1 = PROGRAMMING      2 = READ STATUS ENTRY
(ESCAPE TO ABORT)
```

2. Press the **1** key. The control panel displays the Enter Password screen, as shown below:

```
ENTER PROG OR STAT PASSWORD, THEN ENTER.
_ (ESCAPE TO ABORT)
```

3. Enter **CRT96** and press . The five asterisks that appear when you type in the code will disappear when you press .
4. Press  twice to return to the “SYSTEM NORMAL” screen.
5. To switch back to the default network mode (no CRT) repeat steps 1, 2, and 3 entering **NOCRT**.

Section 3: Status Change

3.1 Overview

Status Change provides a second programming level - accessed by an assigned password - for changing operating parameters. (These operating parameters do not affect control program settings.) For example, the Status Change password lets you change settings such as detector sensitivity and system time and date.



NOTE: Assign the Status Change password to persons who do not have access to Level 1 programming options.

Status Change Options are described below.

Option 1=DISABL - The Disable/Enable option lets you disable programmed points for detectors, modules, zones and NACs. For details, refer to “Disable or Enable a Point” on page 53.

Option 2=SENSITIV - The Detector Sensitivity option lets you change the Alarm and Pre-alarm (sensitivity) level for an installed detector. For details, refer to “Changing Detector Sensitivity” on page 54.

Option 3=CLR VER - The Clear Verification screen lets you clear all counters for detectors selected for Alarm Verification. For details, refer to “Clearing Alarm Verification Counters” on page 55.

Option 4=CLR HIST - The Clear History screen lets you clear the entire History buffer from memory. For details, refer to “Clearing the History Buffer” on page 55.

Option 5=TIME - The Time/Date option lets you set the time and date for the system clock. For details, refer to “Setting the System Time and Date” on page 55.

Option 6=WALK TEST - The Walk Test option lets you test the entire fire alarm system while away from the control panel. For details, refer to “Walk Test” on page 56”.

3.2 How to Enter Status Change

To enter Status Change, follow these steps:

1. From the SYSTEM NORMAL” screen, press the ENTER key. The control panel displays the “Entry” screen, as shown below:

```
1=PROGRAMMING          2=READ STATUS ENTRY
```

2. From the “Entry” screen, press the 1 key. The control panel displays the “Enter Password” screen as shown below:

```
ENTER PROG OR STAT PASSWORD, THEN ENTER.
```

3. Enter your Status Change password (See “How to Enter a Password”, page page 11). The control panel displays the “Status Change Selection” screen, as shown below:

```
STATUS CHANGE PRESS: 1=DISABL 2=SENSITIV  
3=CLR VER 4=CLR HIST 5=TIME 6=WALK TEST
```

4. Select a Status Change selection: **1,2,3,4,5**, or **6**.

3.3 Disable or Enable a Point



WARNING:
Do not rely on disable/enable software settings to lock out releasing devices. Releasing devices must be physically disconnected.



NOTE: When an input or output point associated with releasing functions is disabled, a single supervisory trouble will be generated.



Status Change
Password

The Disable/Enable option lets you disable programmed points for detectors, modules, zones, and NACs. The program allows you to disable an initiating device in alarm; however, the disable will not take effect until after the panel has been reset.



1. From the “Status Change Selection” screen, press the **1** key to display the “Disable/Enable” screen.
2. Select the point type:

- for detectors
- for modules
- for NACs
- for zones

The cursor will blink the first SLC address digit in the detector, zone, module, or NAC field.



WARNING:
Disabling a zone disables all input and output devices that use the zone as the first entry in the CBE list.

3. Enter the address of the point, then press the ENTER key. A sample display follows:

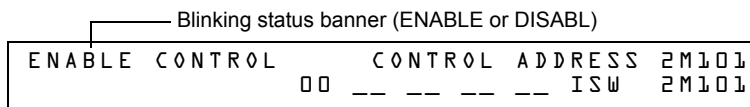

When you disable a point and press the ESC key to return to the Disable/Enable screen, the control panel: a) turns on the POINT DISABLED LED; b) sounds the panel sounder; and c) changes the status banner to TROUBL for the point.

You can disable or enable a point by changing the status banner as follows:

Table 3.1 Changing the Status Banner (1 of 2)

To	Press
Change the status	Maneuver the cursor with the arrow keys until it is in the status field. Press (Next Selection) or (Previous Selection)

Table 3.1 Changing the Status Banner (2 of 2)

To	Press
Save the status	
Go to the next or previous point address	(Next Selection) or (Previous Selection)

3.4 Changing Detector Sensitivity

The Detector Sensitivity option lets you change the Alarm and Pre-Alarm (sensitivity) level for an installed detector. From the “Status Change Selection” screen, press the **2** key to display the “Detector Selection” screen as shown below:

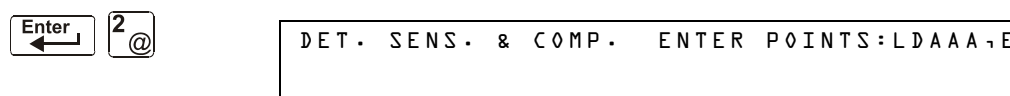

To select a detector, enter the SLC address (2D101) of an installed detector in the “LDAAA” field (shown above). The control panel displays the following screen:

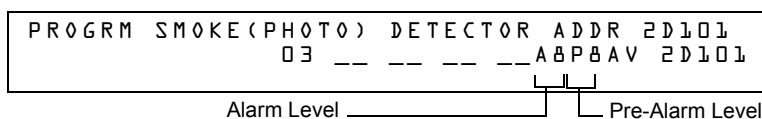

Use the instructions below to set/change detector sensitivity, display additional detectors, and set Pre-alarm values.



NOTE: If not using Pre-Alarm, set PA=0. PA=1 is the self-optimizing mode. For details, refer to “Pre-Alarm” on page 99.

To	Enter or Press
Display detector information on the screen.	The detector address, then press .
Set alarm sensitivity level.	A value (1-9) or increase or decrease values by pressing the NEXT or PREVIOUS keys: or .
Set Pre-alarm level	A value (0-9) or increase or decrease values by pressing the NEXT or PREVIOUS keys: or .
Save the sensitivity values.	
Display the next existing detector address.	(Next Selection)
Display the previous existing detector address.	(Previous Selection)

3.5 Clearing Alarm Verification Counters

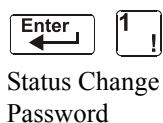

The Clear Verification screen lets you clear all counters for detectors selected for Alarm Verification. From the “Status Change Selection” screen, press the 3 key to display the “Clear Verification” screen as shown below:

```
PRESS ENTER TO CLEAR VERIFICATION COUNTS
OR ESCAPE TO ABORT
```

From the Clear Verification screen, you can do the following:

- Press the ENTER key to clear all verification counters and return to the “Status Change Selection” screen; or
- Press the ESC key to return to the “Status Change Selection” screen without clearing.

3.6 Clearing the History Buffer



The Clear History screen lets you clear the entire History buffer from memory. Press the 4 key from the “Status Change Selection” screen to display the “Clear History” screen as shown below:

```
PRESS ENTER TO CLEAR HISTORY FILE
OR ESCAPE TO ABORT
```

From the Clear History screen, you can do the following:

- Press the ENTER key to clear the contents of the History buffer and return to the “Status Change Selection” screen; or
- Press the ESC key to return to the “Status Change Selection” screen without clearing.

3.7 Setting the System Time and Date

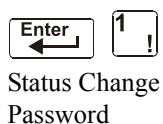

The Time/Date option lets you set the time and date for the system clock. Press the 5 key from the “Status Change Selection” screen to display the “Time/Date” screen as shown below:

```
CHANGE TIME/DATE      11:40A Tue 04/15/2008
```

The first digit flashes until you change the value or press the ENTER key. To set the system time and date, follow the instructions below:

To	Do this
Change the time and date values	Enter values from the numeric keys on the keypad.
Change A (AM) or P (PM)	Press (Next Selection) or (Previous Selection)
Change the day	Press (Next Selection) or (Previous Selection)
Move to another digit	Press

To	Do this
Save the time and date and return	Press 

3.8 Walk Test

Walk Test allows the user to test the entire fire alarm system. There are two kinds of Walk Test - Basic and Advanced, described later in this section.

Before entering Walk Test, note the following:

- For each individual activation, the control panel sends “TEST Axx” (for alarm testing) or TEST Txx (for trouble testing) to the History buffer, installed printers and CRT-2s so results can be reviewed.
- Basic Walk Test, Silent – In order to keep the test silent, do not program any of the output modules with “W” in the Walk Test field.
- Advanced Walk Test - This test overrides a setting of “*” (silent) in the Walk Test field. All activated outputs will sound until panel reset.
- The control panel provides a 1-hour timer for Walk Test mode. When the hour expires with no activity, the control panel automatically returns to normal operation.
- Walk Test may be exited at any time by pressing the ESC key.



WARNING:

Walk Test mode deactivates fire protection. Always observe the following:

1. Prior to Walk Test, secure all protected buildings, and notify the building owner/operator, fire department, and other pertinent personnel that testing is in progress.
2. Immediately after Walk Test is completed, notify the same people that testing is complete and is restored to normal operation.



WARNING:

Physically disconnect all releasing devices before starting Walk Test. It is not sufficient to disable in any other manner.



NOTE: Walk Test will not start if any devices are active (i.e., fire alarms, security, supervisories or pre-alarms.) To perform a walk test while a device is active, disable the device and press the System Reset button.



For information on programming Walk Test field selections, refer to “Modify an Addressable Monitor Module Point” on page 22 or “Modify NAC Points” on page 24.

3.8.1 Basic Walk Test

When the tester activates an input during Basic Walk Test, all silenceable outputs mapped by CBE to that input will activate. The activations are tracking; once the activation stimulus is removed, the input will deactivate. Basic Walk Test may be audible or silent, depending on the Walk Test setting of participating outputs. Program the Walk Test field for control modules and NACs as follows:



For	Program Silenceable Outputs with	Silenceable Outputs will
an audible Basic Walk Test	W	sound for approximately 4 seconds during Walk Test
a silent Basic Walk Test	*	not sound during Walk Test
a trouble Basic Walk Test	W	sound for approximately 8 seconds when put into trouble

Enter Basic Walk Test in the following manner:



  From the “Status Change Selection” screen, press the **6** key. The control panel displays the “Walk Test” screen as shown below:

Status Change Password

WALK TEST	PRESS ENTER TO START
ESCAPE TO ABORT	

Operate the control panel in Walk Test as follows

To	Press
Put the control panel into Walk Test mode	
Stop a Walk Test and return to the “Status Change Selection” screen	

Basic Walk Test directs the control panel to do the following:

- Activate silenceable outputs associated by programming with each new alarm. (The panel does not activate non-silenceable outputs.)
- Save and store each test in the History buffer
- Send a TEST Axx status banner for each alarm, and a TEST TXX banner for each trouble, to the printer (xx equals the number of tests for a detector or input device with this address)
- Turn on the System Trouble LED
- Turn on the System Trouble relay
- Disable activation of the System Alarm relay

3.8.2 Advanced Walk Test

During Advanced Walk Test, when the tester activates an input, all CBE mapped to that input will activate with the exception of releasing functions. Each input activation is latching; that is, it will not deactivate until the system is reset. Advanced Walk Test will sound all activated outputs, overriding a setting of “*” (silent) in the Walk Test field.



NOTE: Some detectors, laser detectors for example, can be difficult to place in alarm using a magnet. Advanced Walk Test facilitates magnet testing of these detectors.

Enter Advanced Walk Test as follows:

Enter LTEST at the password screen. Asterisks will display where LTEST has been typed. Pressing ENTER displays the following screen.

LTEST

--	--

	<pre> TROUBL IN SYSTEM ADV WALK TEST PROCESSING DISABLED 10:07a 041508 MON </pre>
--	---



NOTE: The control panel can not be put into Walk Test from an alarm condition.

To	Press
Stop an Advanced Walk Test and return to the "Status Change Selection" screen	

Advanced Walk Test directs the control panel to do the same as it does for Basic Walk Test (see "3.8.1, "Basic Walk Test" above) with the following exceptions:

- alarm and trouble messages are sent to the printer, not test messages. (These Walk Test messages can be distinguished from others at the printer because they begin with the trouble message generated when Walk Test is entered, and end with the cleared trouble when Walk Test is exited.)
- all CBE mapped to the test input is activated except releasing functions.

3.8.3 Walk Test Activation Indications

Walk Test Activation Indications

FlashScan poll mode - Once the test is started:

- each intelligent addressable input device will blink its address in red, and each intelligent addressable output device will blink its address in green. Pattern examples are given below.

Address	Blink Pattern
8	8 blinks, long stop, 8 blinks, long stop,....
37	3 blinks, stop, 7 blinks, long stop, 3 blinks, stop, 7 blinks, long stop,....
70	7 blinks, stop, 10 blinks, long stop, 7 blinks, stop,.....
107	10 blinks, stop, 7 blinks, long stop, 10 blinks, stop,.....
152	15 blinks, stop, 2 blinks, long stop, 15 blinks, stop, 2 blinks, long stop....

- an input device activated in Basic Walk Test latches on steady green for the duration of the test.
- an output device activated in Basic Walk Test will remain active and the LED will glow steady green for:
 - approximately 4 seconds for alarms
 - approximately 8 seconds for troubles.
- an output device activated in Advanced Walk Test will remain active and the LED will glow steady green until the reset key is pressed.

CLIP mode - Once the test is started:

- intelligent addressable input and output devices continue to blink red as usual until activated.
- an input device activated in Basic Walk Test latches on steady red during activation. If the device is put in trouble (for instance, the detector head is removed, then replaced), the LED will be latched on for the duration of the test.
- an output device activated during Basic Walk Test will remain active and the LED will glow steady green (if a FlashScan module) or steady red (if a CLIP module) for:
 - approximately 4 seconds for alarms
 - approximately 8 seconds for troubles.
- an output device activated in Advanced Walk Test will remain active and the LED will glow steady green (if a FlashScan module) or steady red (if a CLIP module) until the reset key is pressed.

3.8.4 Viewing Walk Test Results

When finished with a Walk Test, view the History buffer, installed printers and CRT-2s to check the results of the Walk Test. View the History buffer by using the Read Status function. From the SYSTEM NORMAL screen, press the ENTER key, press the **2** key two times, then press the ENTER key to view the History buffer. For further instructions on using the Read Status function, refer to the *NF2S-640 Operations Manual*.

Appendix A: Releasing Applications



WARNING:

When used for CO₂ releasing applications, observe proper precautions as stated in NFPA 12. Do not enter the protected space unless physical lockout and other safety procedures are fully completed.

Do not use software disable functions in the panel as lockout.

Do not enable the BACKUP option switch for any of the four Notification Appliance Circuits (NACs) if they are used for releasing functions.

A.1 Overview

A.1.1 Description of Releasing Zones

The control panel includes ten Releasing Zones (R0-R9) that can be used to control up to ten releasing operations. Each zone operates independently, and is fully programmable..



NOTE: Releasing Zones R0-R9 appear in the CBE list of devices as ZR0-ZR9. For example, if you list R5 for a detector, one of the five zones in the CBE list of the detector will display as ZR05.

From the “Special Function Change” screen (refer to “Program Special Zones (6=spl funct)” on page 27), select a Releasing Zone (R0-R9) to display the “Releasing Function” screen:

```
PRG RELEASE FUNCTION RELEASE CONTROL  
DELAY=30 ABORT=ULI CROSS=N SOK=0000 R05
```

Each Releasing Zone includes four releasing functions, outlined below:

Table A.1 Releasing Zone Functions

Function	Lets You
Delay	Program a 01 to 60-second Delay Timer (or 00, no delay). The Delay Timer equals the time that must elapse between activating an initiating device and activating the releasing zones mapped to the active initiating device. Refer to “Programming a Delay Timer” on page 61.
Abort	Select a 3-letter Abort switch Type Code (ULI, IRI, NYC, or AHJ) that adds a delay time to a Releasing Zone, or prevents a release of a Releasing Zone. Refer to “Abort Switches” on page 62.
Cross	Select one of three Cross Zone types or “N” (not used). A Cross Zone requires tripping two or more devices to activate the outputs mapped to one of the Releasing Zones. Refer to “Using Cross Zones” on page 70.
Soak	Select a Soak Timer (0001-9999 seconds) or “0000” (not used). Refer to “Programming a Soak Timer” on page 72.

A.1.2 NFPA Releasing Applications

This control panel can be used for agent release or preaction/deluge control applications. In a properly configured system with compatible, listed actuating and initiating devices, this control panel complies with the following NFPA standards for installation in accordance with the acceptable standard:

Table A.2 NFPA Standards for Releasing Applications

Standard	Covers
NFPA 12	CO ₂ Extinguishing Systems
NFPA 12A	Halon 1301 Extinguishing Systems
NFPA 13	Sprinkler Systems, Installation of
NFPA 15	Water Spray Fixed Systems
NFPA 16	Foam-water Deluge and Foam-water Spray Systems
NFPA 17	Dry Chemical Extinguishing Systems
NFPA 17A	Wet Chemical Extinguishing Systems
NFPA 2001	Clean Agent Fire Extinguishing Systems

A.2 How to Program a Releasing Zone

This section provides details for programming the releasing functions: Delay Timer, Abort Switch, Cross Zone, and Soak Timer.

A.2.1 Programming a Delay Timer

Use a Delay Timer to specify the elapsed time between alarm activation of an initiating device and activation of all output devices programmed as release circuits and mapped to that initiating device. You can set the Delay Timer from 01 to 60 seconds, or to 00 for no delay. The figure below shows graphical representation of a 15-second timer:

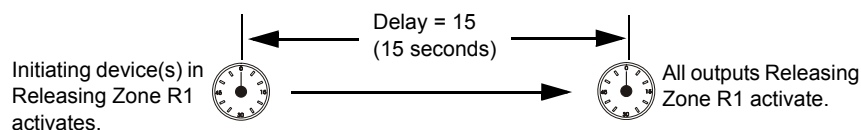

Figure A.1 Example of 15-Second Delay Timer

To Program	Do this
Delay Timer	Enter a value (00-60) from the numeric keys on the keyboard.

Press at this point to save the Delay Timer value if no other fields on the screen are changing. To change another field on the screen, move the cursor into position by pressing the arrow keys.

A.2.2 Abort Switches

Definition of Abort Switches

The control panel provides for four (4) types of Abort Switches (ULI, IRI, NYC, and AHJ) that you can use, that will affect the operation of a Delay Timer mapped to the same Releasing Zone. For example, an Abort Switch selected for Releasing Zone R05 only affects the Delay Timer selected for R05. Other requirements for using an Abort Switch include the following:

- Connecting a monitor module to a UL-listed abort station, such as the NBG-12LRA shown below.
- Program the monitor module with the Type Code ABORT SWITCH. (Refer to “Modify an Addressable Monitor Module Point” on page 22.)
- Abort switch shall not be used with a preaction system or a CO₂ system.

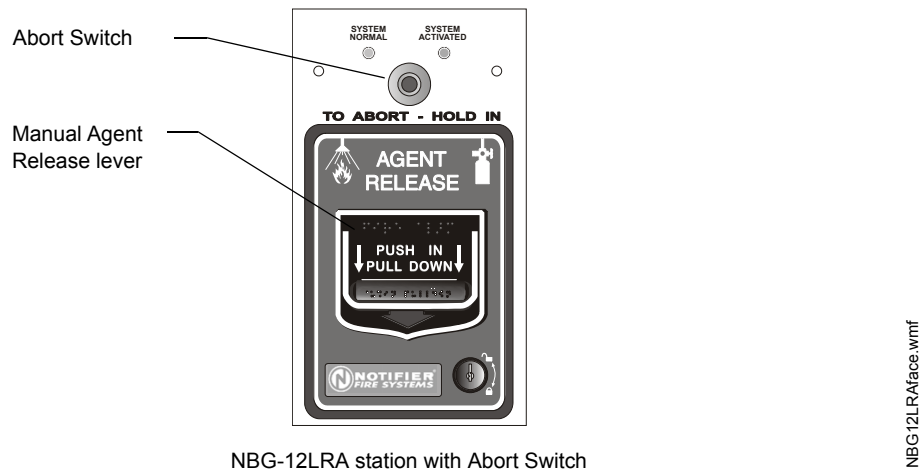

NBG-12LRA station with Abort Switch

Figure A.2 UL-listed Abort Station

This section contains information for programming each type of Abort Switch for a Releasing Zone.

How an Abort Switch Works

The figure below contains an example for configuring an Abort Switch and shows the requirements for using an Abort Switch for Releasing Zone R05, which are:

- A monitor module is wired to an abort station
- The monitor module is programmed with the Type Code, ABORT SWITCH
- All initiating devices and outputs are mapped to a common Releasing Zone (R05 shown)
- Releasing Zone R05 is programmed with the releasing functions: Delay, Abort, Cross, and Soak



NOTE: The abort switch can only be associated with one releasing zone.

When an initiating device activates, you must press and hold the Abort Switch or the control panel will send the command to dump releasing agents when the Delay time (15 seconds shown) expires. The Abort selection (ULI, IRI, NYC, or AHJ) determines the function of the Abort Switch.

```

PRG RELEASE FUNCT  RELEASE CONTROL
DELAY=15  ABORT=ULI  CROSS=N  SOK=0000  R05
    
```

Releasing Zone R05 sample programming selections

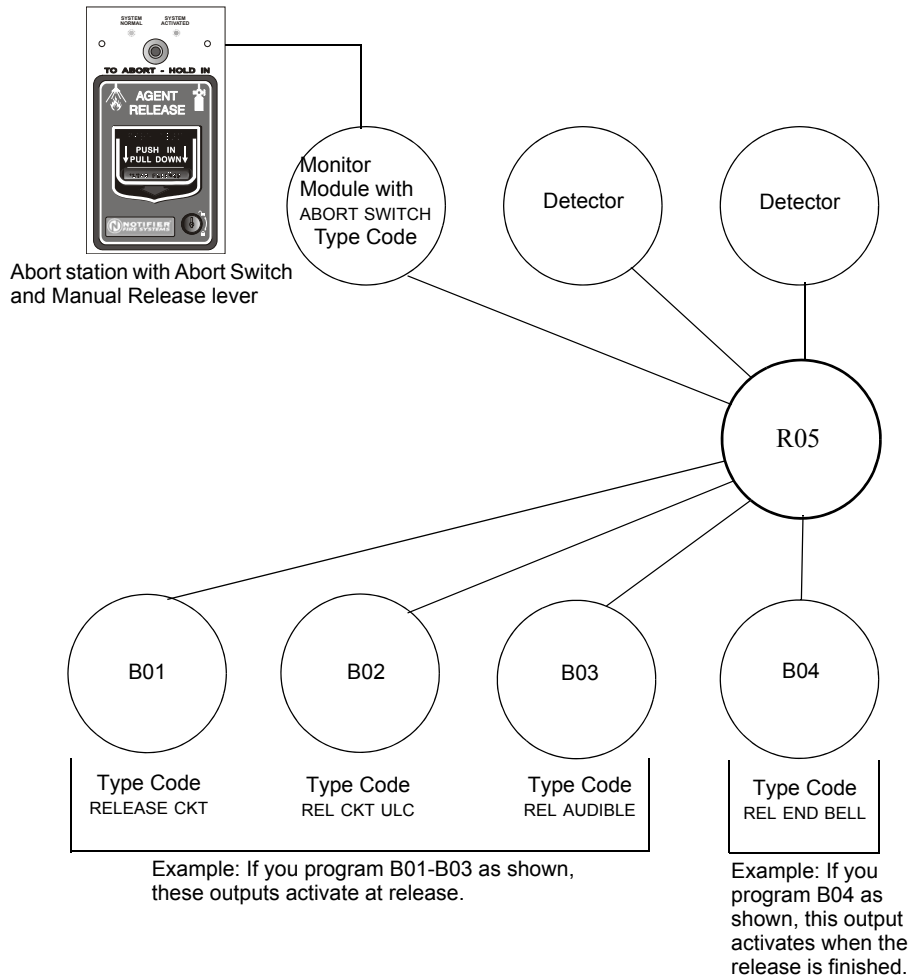

Figure A.3 Example of a Basic Configuration for an Abort Switch

Programming a ULI Abort Switch

The following contains information needed to program a ULI Abort Switch.

■ Description

Requires a standard UL-type delay timer that complies with UL Standard 864.

■ How to Program

1. Program the monitor module connected to the abort station with the Type Code ABORT SWITCH as detailed in “Modify an Addressable Monitor Module Point” on page 22.
2. Select a time for the Releasing Zone Delay Timer (refer to “Programming a Delay Timer” on page 61).

To Program	Do this
ULI Abort Switch	Type ULI in the ABORT= field, or press the NEXT or PREVIOUS keys: <input type="button" value="+"/> or <input type="button" value="-"/> until ULI appears in the field.

3. Press at this point to save the Abort Switch value if no other fields on the screen are changing. To change another field on the screen, move the cursor into position by pressing the arrow keys on the keypad.

■ How It Works

When an alarm initiates in the programmed Releasing Zone, you can press and hold the Abort Switch while the Delay Timer continues to count down. (If the delay timer has expired, the abort switch has no effect.) When you release the Abort Switch, a 10-second ULI timer counts down. At the end of the 10-second ULI timer, the control panel activates the Releasing Zone outputs.

■ Example

A ULI Abort Switch and a Delay Timer programmed to Releasing Zone R05:

```
PRG RELEASE FUNCT  RELEASE CONTROL
DELAY=15  ABORT=ULI  CROSS=N  SOK=0000  R05
```

Program selections for Releasing Zone R05

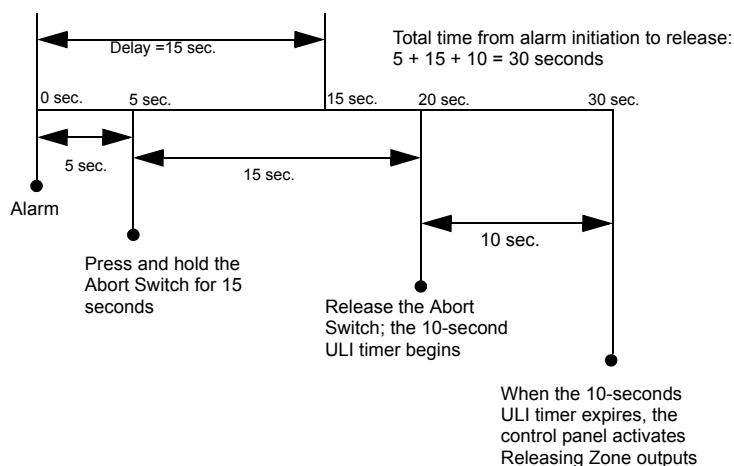

Figure A.4 ULI Abort Switch Example

Programming an IRI Abort Switch

The following contains information needed to program an IRI Abort Switch.

■ Description

A standard UL-type delay timer (complies with UL Standard 864) that operates like ULI, but with additional functions for Cross Zones.

■ How to Program

1. Program the monitor module connected to the abort station with Type Code ABORT SWITCH as detailed in “Modify an Addressable Monitor Module Point” on page 22.
2. Select a time for the Releasing Zone Delay Timer (refer to “Programming a Delay Timer” on page 61.)

To Program	Do this
IRI Abort Switch	Type IRI in the ABORT= field, or press the next or previous keys, <div style="display: flex; align-items: center; justify-content: center;"> + or - </div> , until IRI appears in the field.

3. Press  at this point to save the Abort Switch value if no other fields on the screen are changing. To change another field on the screen, move the cursor into position by pressing the arrow keys on the keypad.

■ How it Works

When the first alarm occurs in a releasing zone programmed with a cross-zone code, pressing the abort switch will prevent activation of the releasing zone should a second alarm occur while the switch is held. When the abort switch is released, if a second alarm has occurred while the switch was held, the ten-second IRI timer activates immediately, and the control panel activates the releasing zone outputs at the end of the IRI timer countdown. When the abort switch is released and a second alarm has not occurred while the switch was held, the panel waits for the cross-zone conditions to be met before activating the releasing zone.



WARNING:

The IRI abort switch will only work if it is pushed before the second alarm occurs. If it is pushed after the second alarm, the releasing zone will already have been activated, and the switch will have no effect.

■ Example

An IRI Abort Switch and a Delay Timer programmed to Releasing Zone R05:

```

PRG RELEASE FUNCT  RELEASE CONTROL
DELAY=15 ABORT=IRI  CROSS=Z  SOK=0000  R05
    
```

Program selections for Releasing Zone R05

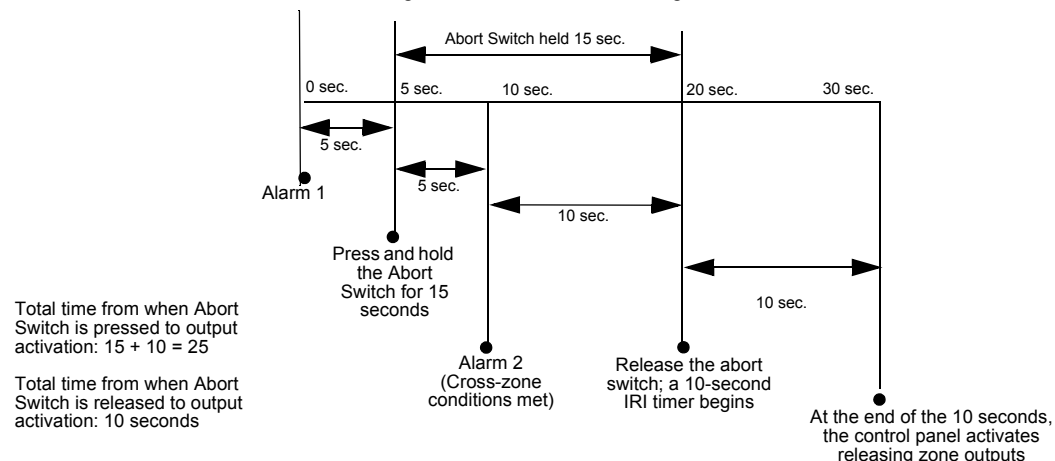

Figure A.5 IRI Abort Switch Example

Programming a NYC Abort Switch

The following contains information needed to program an NYC Abort Switch.

■ Description

A standard NYC delay timer that adds 90 seconds to the programmed Delay Timer.



NOTE: NYC timers do not comply with UL Standard 864.

■ How to Program

1. Program the monitor module connected to the abort station with the Type Code ABORT SWITCH as detailed in “Modify an Addressable Monitor Module Point” on page 22.
2. Select a time for the Releasing Zone Delay Timer (refer to “Programming a Delay Timer” on page 61.)

To Program	Do this
NYC Abort Switch	Type NYC in the ABORT= field, or press the next or previous keys, <input type="button" value="+"/> or <input type="button" value="-"/> , until NYC appears in the field.

3. Press at this point to save the Abort Switch value if no other fields on the screen are changing. To change another field on the screen, move the cursor into position by pressing the arrow keys on the keypad.

■ How It Works

When an alarm initiates in the programmed Releasing Zone, pressing and holding the Abort switch stops the Delay Timer countdown. The Delay Timer restarts at the beginning of its countdown when the Abort switch is released. When the Delay Timer expires, the 90-second NYC timer starts counting down. When both timers expire, the control panel activates Releasing Zone outputs.



NOTE: 120 seconds is the maximum delay after the Abort switch is released. If the Delay Timer time plus the NYC delay time of 90 seconds exceeds 120 seconds, Releasing Zone outputs will still be activated at 120 seconds after the Abort switch is released.

■ Example 1 - Delay Time Does Not Exceed 120 Seconds

Select a Delay Timer value for R05 of 15 seconds. The Releasing Zone activates and the 15-second Delay Timer starts. Ten seconds into the Delay Timer countdown, press and hold the Abort Switch for 30 seconds, then release the Abort Switch. The control panel restarts the Delay Timer at 15 seconds and adds the NYC delay of 90 seconds. The delay timers will both expire at 105 seconds,

and Releasing Zone outputs will begin releasing at that time. Following is an example of a NYC Abort Switch and a Delay Timer programmed to Releasing Zone R05:

```
PRG RELEASE FUNCTION RELEASE CONTROL
DELAY=15 ABORT=NYC CROSS=N SOK=0000 R05
```

Program selections for Releasing Zone R05

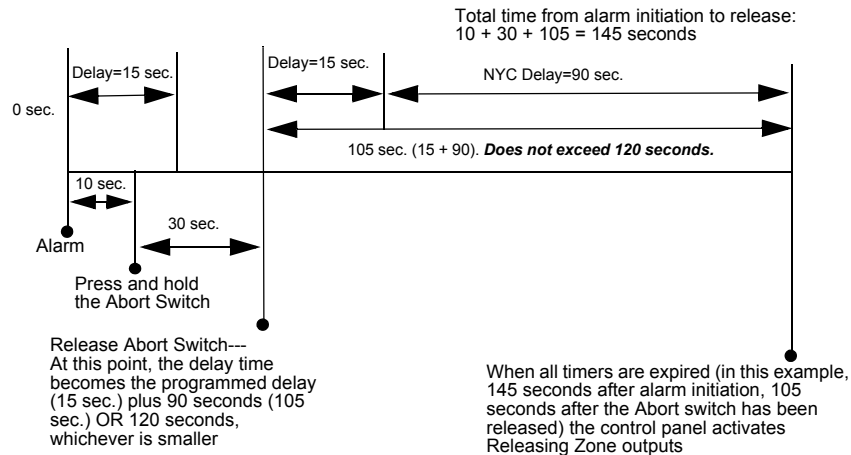

Figure A.6 NYC Abort Switch Example 1

■ Example 2 - Delay Time Exceeds 120 Seconds

Select a Delay Timer value for R05 of 60 seconds. The Releasing Zone activates and the 60-second Delay Timer starts. Ten seconds into the Delay Timer countdown, press and hold the Abort Switch for 30 seconds, then release the Abort Switch. The control panel restarts the Delay Timer at 60 seconds and adds the NYC delay of 90 seconds. The delay timers will both expire at 150 seconds; however, this time exceeds the maximum of 120 seconds, so the Releasing Zone outputs will begin releasing at 120 seconds, not at 150. Following is an example of a NYC Abort Switch and a Delay Timer programmed to Releasing Zone R05:

```
PRG RELEASE FUNCTION RELEASE CONTROL
DELAY=60 ABORT=NYC CROSS=N SOK=0000 R05
```

Program selections for Releasing Zone R05

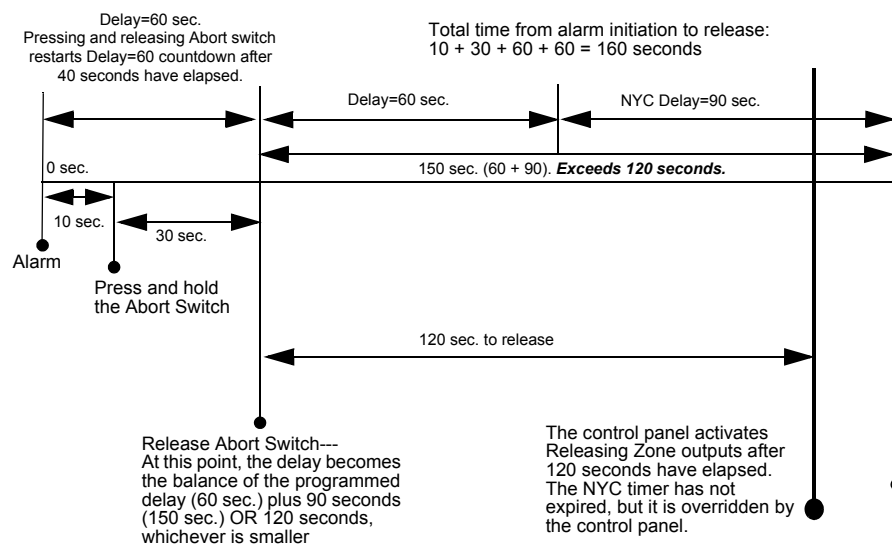

Figure A.7 NYC Abort Switch Example 2

Programming an AHJ Abort Switch

The following contains information needed to program an AHJ Abort Switch:

■ Description

An AHJ (Authority Having Jurisdiction) delay timer that restores the programmed Delay Timer.



NOTE: An AHJ timer does not comply with UL Standard 864.

■ How to Program

1. Program the monitor module connected to the abort station with the Type Code ABORT SWITCH as detailed in “Modify an Addressable Monitor Module Point” on page 22.
2. Select a time for the Releasing Zone Delay Timer (refer to “Programming a Delay Timer” on page 61).

To Program	Do this
AHJ Abort Switch	Type AHJ in the ABORT= field, or press the NEXT or PREVIOUS keys, <input type="button" value="+"/> or <input type="button" value="-"/> , until AHJ appears in the field.

3. Press at this point to save the Abort Switch value if no other fields on the screen are changing. To change another field on the screen, move the cursor into position by pressing the arrow keys on the keypad.

■ How It Works

When an alarm initiates, the programmed Delay Timer starts. Press and hold the Abort switch and the control panel suspends the Delay Timer. When you release the Abort Switch, the control panel restores the value of the programmed Delay Timer and the Delay Timer counts down. When the Delay Timer expires, the control panel activates Releasing Zone outputs.

■ Example

An AHJ Abort Switch and a Delay Timer programmed to Releasing Zone R05:

```

PRG RELEASE FUNCTION RELEASE CONTROL
DELAY=60 ABORT=AHJ CROSS=N SOK=0000 R05
    
```

Program selections for Releasing Zone R05

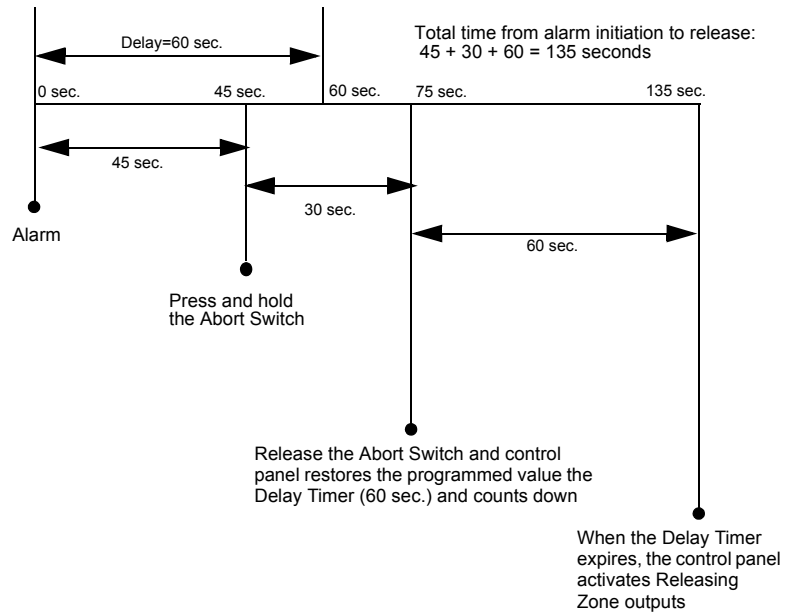

Figure A.8 AHJ Abort Switch Example

A.2.3 Using Cross Zones

Purpose of Cross Zones

Using Cross Zones lets you program the control panel to activate a Releasing Zone and any output mapped to the Releasing Zone only after a predetermined sequence of events occurs. (If not using Cross Zones, set CROSS= N.)



NOTE: Only the first Software Zone (Z01-Z99) listed in the zone map is used to determine Cross=Z.

A summary of the types of Cross Zones and the conditions for activating a Releasing Zone:

Type	Activates when
Y	Two or more detectors or modules are alarmed that are mapped to one of the ten Releasing Zones (R0-R9).
Z	Two or more detectors or modules are alarmed that are mapped to two different software zones and mapped to one of the ten Releasing Zones (R0-R9).
H	At least one smoke detector or module mapped to one of the ten Releasing Zones (R0-R9) is alarmed and at least one heat detector mapped to the same Releasing Zone (R0-R9) is alarmed.



NOTE: When in alarm, Special Zones R0-R9 appear in the CBE list as ZR00-ZR09. For example, R5 appears in the CBE list as ZR05.

How Cross Zones Work

Below is an illustrated example of how Cross Zones work, using five Cross Zone selections (four detectors and a NAC mapped to Releasing Zone R1):

```

PROGRAM SMOKE(PHOTO) DETECTOR ADDR 2D101
          01 R1  __ __ __ ABPB** 2D101
CBE list = 01 R1  _____

PROGRAM SMOKE(PHOTO) DETECTOR ADDR 2D102
          01 R1  __ __ __ ABPB** 2D102
CBE list = 01 R1  _____

PROGRAM SMOKE(PHOTO) DETECTOR ADDR 2D103
          02 R1  __ __ __ ABPB** 2D103
CBE list = 02 R1  _____

PROGRAM HEAT(ANALOG) DETECTOR ADDR 2D104
          02 R1  __ __ __ ** 2D104
CBE list = 02 R1  _____

PROGRAM RELEASE CKT FRONT HALLWAY NO. 3
          R1  __ __ __ __ I** B03
CBE list = R1  _____

```

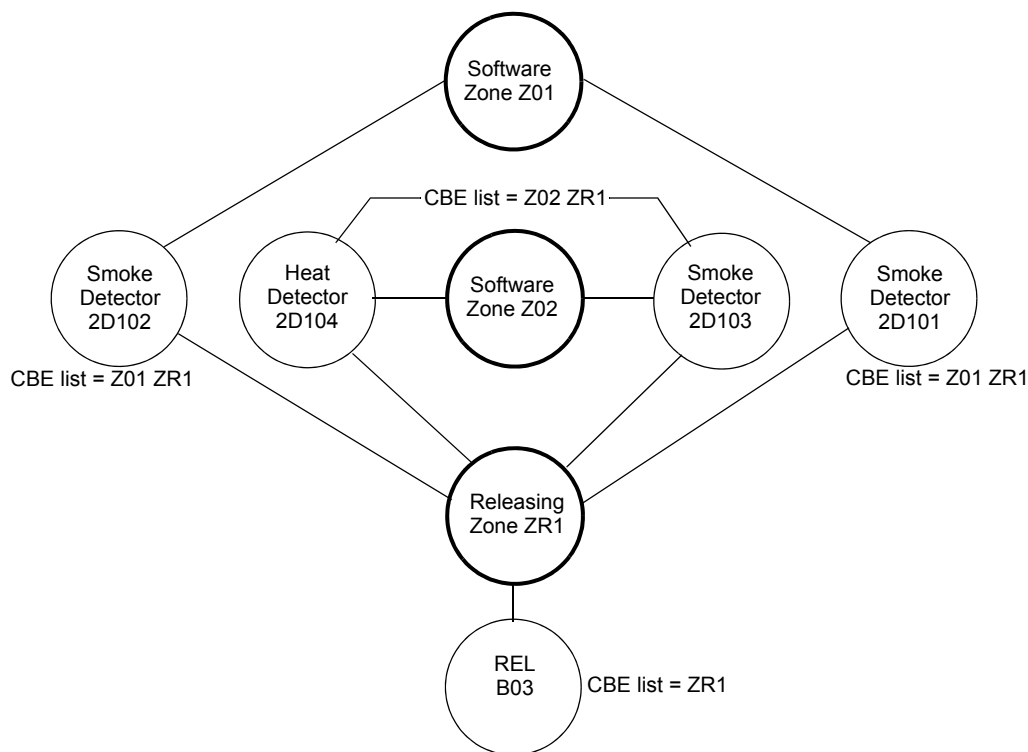



Figure A.9 Illustrated Example of Cross Zone Programming

A listing of each Cross Zone option and the conditions required to activate the Releasing Zone, according to the example shown above.

Cross Zone Selection (Cross=)	Condition(s) Required to Activate the Releasing zone
Cross=N	An alarm from any detector or module activates the releasing circuit.
Cross=Y	An alarm from any two detectors or modules activates the releasing circuit.
Cross=Z	An alarm from two detectors or modules mapped to different Software Zones, but mapped to the same Releasing Zone. <ul style="list-style-type: none"> • An alarm from 2D101 and 2D103 • An alarm from 2D102 and 2D104 • An alarm from 2D101 and 2D104 • An alarm from 2D102 and 2D103 The two detectors listed in each set above are each mapped to different zones, but both list ZR1 in their CBE.
Cross=H	Activation of heat detector 2D104 and one smoke detector (2D101, 21D102, or 2D103) or a module mapped to the same releasing zone.

Select a time for the Releasing Zone Delay Timer (refer to “Programming a Delay Timer” on page 61.)

To Program	Do this
Cross Zones	Type N, Y, Z, or H in the CROSS= field, or press the NEXT or PREVIOUS keys, <input type="button" value="+"/> or <input type="button" value="-"/> , until N, Y, Z or H appears in the that field.

Press  at this point to save the Cross Zone value if no other fields on the screen are changing. To change another field on the screen, move the cursor into position by pressing the arrow keys on the keypad.

A.2.4 Programming a Soak Timer

The Soak Timer specifies the length of time (0001 to 9999 seconds, or 0000 for not used) to dump releasing agents when a Releasing Zone activates. When the Soak Timer expires, the control panel automatically shuts off the releasing solenoids for the active Releasing Zone. To program a Soak Timer for a Releasing Zone, follow these instructions:

To Program	Do this
Soak Timer	Type a seconds value of 0000 (no soak timer) to 9999 from the numeric keys on the keypad in the SOK= field.

Press  at this point to save the Soak Timer value if no other fields on the screen are changing. To change another field on the screen, move the cursor into position by pressing the arrow keys on the keypad.

A Soak Timer value of 600 seconds is shown below:

```
PRG RELEASE FUNCTION RELEASE CONTROL
DELAY=00 ABORT=ULI CROSS=N SOK=0600 R00
```

A.2.5 Using Type Codes for Releasing Zones

The control panel provides a set of Type Codes designed for releasing applications for inputs and outputs. This section details how to program each of these Type Codes.

Type Codes designed for Releasing Zone **inputs** (monitor modules).

Type Code	What the Type Code does	Refer to
ABORT SWITCH (tracking)	Provides an abort function through a monitor module (connected to a UL-listed abort station) for a Releasing Zone.	"abort switch Type Code" on page 74
MAN. RELEASE (latching)	Provides a manual release through a monitor module (connected to a UL-listed pull station) for a Releasing Zone.	"man. release Type Code" on page 75
MAN REL DELAY (latching)	Provides a manual release with a 30-second delay (dependent on the FACP Delay setting) through a monitor module (connected to a UL-listed pull station) for a Releasing Zone.	"manrel delay Type Code" on page 76
SECOND SHOT (latching)	Provides a second manual release through a monitor module (connected to a UL-listed pull station) for a Releasing Zone.	"second shot Type Code" on page 78

Type Codes designed for Releasing Zone **outputs** (control modules and panel NACs).

Type Code	What the Type Code does	Refer to
REL END BELL	Activates a NAC audio or visual device when releasing circuits shut off.	"release end bell" on page 79
REL CKT ULC	Directs outputs to perform a release function as required by ULC.	"rel ckt ulc Type Code" on page 81
RELEASE CKT	Directs outputs to perform a releasing function.	"release ckt Type Code" on page 83
RELEA. FORM C	Directs relay outputs to perform a releasing function.	"Relea. Form-C Type Code" on page 85
REL AUDIBLE	Activates audio or visual devices steady when releasing starts.	"rel audible Type Code" on page 87
INSTANT RELE	Activates non-releasing output (panel NAC or control modules) with no delay time.	"instant rele Type Code" on page 89
REL CODE BELL	Activates audio or visual devices to pulse at 20 ppm (initial zone of a Cross Zone) or 120 ppm (Cross Zone satisfied). Steady on release.	"REL CODE BELL Type Code" on page 90

ABORT SWITCH Type Code

The following contains information needed to program an Abort Switch for a monitor module

■ Description

A monitor module, connected to a UL-listed abort station (such as the Notifier NBG-12LRA), that you use as an abort switch for a Releasing Zone. You can program multiple monitor modules with the ABORT SWITCH Type Code that work like multiple conventional abort switches on a conventional zone.

■ Programming

1. Select a monitor module to use as an Abort Switch (refer to “Modify or Delete a Point (2=point)” on page 19).
2. Select the ABORT SWITCH Type Code.

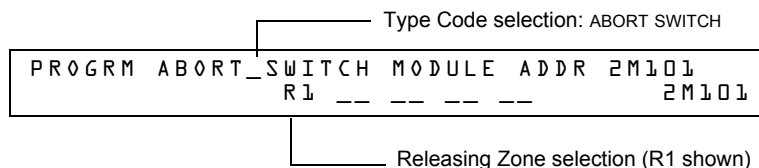

3. Select the Releasing Zone (R0-R9) for your releasing application.
4. Press the enter key to save, then press the esc key until you return to the Program Change screen.
5. Select the type of Abort Switch for your releasing application (refer to “Abort Switches” on page 62).

■ Example

A programming example of a monitor module programmed as an Abort Switch for Releasing Zone R5.

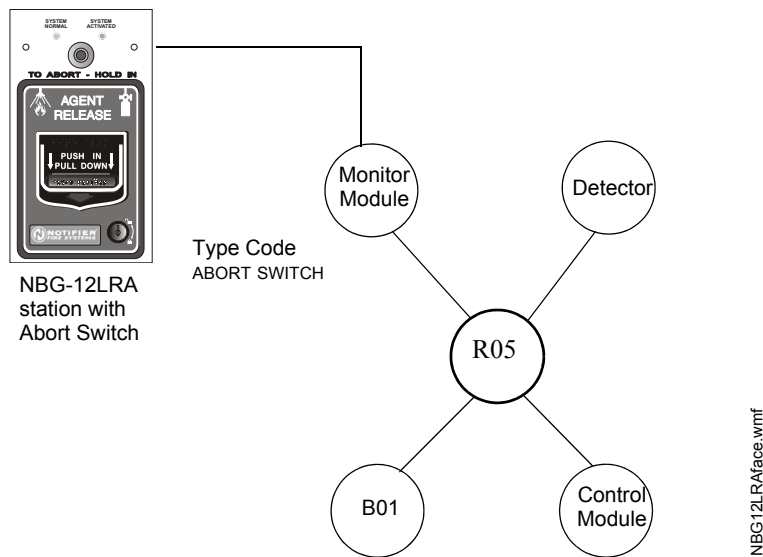

Figure A.10 Monitor Module Configured as an Abort Switch

MAN. RELEASE Type Code

The following contains information needed to program a Manual Release switch for a monitor module.

■ Description

A monitor module—connected to a UL-listed manual station (such as the Notifier NBG-12LRA)—used to manually release agents. A Manual Release switch overrides all timers, such as a Delay Timer or a Soak Timer. You can install multiple monitor modules with a MAN. RELEASE Type Code that work like multiple conventional manual release switches on a conventional zone.

■ Programming

1. Select a monitor module (refer to “Modify or Delete a Point (2=point)” on page 19) to use for the manual release function.
2. Select the MAN. RELEASE Type Code.

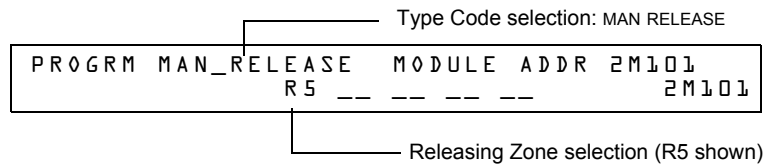

3. Select the Releasing Zone (R0-R9) for your releasing application.
4. Press the ENTER key to save, then press the ESC key until you return to the Program Change screen.

■ Example

A programming example of a monitor module programmed as an manual release switch for Releasing Zone R5.

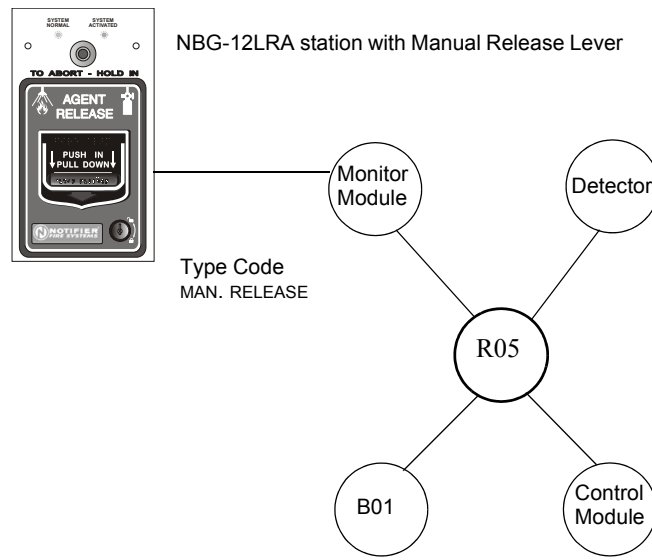

Figure A.11 Monitor Module Configured as a Manual Release Switch

MANREL DELAY Type Code

The following contains information needed to program a Manual Release Delay switch for a monitor module using the MANREL DELAY Type Code.

■ Description

A monitor module—connected to a UL-listed manual station (such as the Notifier NBG-12LRA)—used to initiate a manual release with 30-second delay time.

A Manual Release Delay switch overrides the FACP programmed Delay Timer in certain circumstances, but not the soak timer.

Override Circumstances:

When the Manual Release Delay Switch activates, the control panel replaces the Delay Time with 30 seconds if the Delay Timer

- is set to more than 30 seconds
- is running, *and*
- has not counted down below 30 seconds.



NOTE: When the Delay Timer is set to less than 30 seconds, activation of the Manual Release Delay Switch will invoke the FACP programmed Delay Time if the Delay Timer is not running, or the FACP programmed Delay Timer countdown time if it is running. Refer to the examples 1 through 5 later in this section.

Multiple monitor modules can be programmed with a MANREL DELAY Type Code. They work like multiple conventional manual release switches on a conventional zone.

■ How to program

1. Select a monitor module (refer to “Modify or Delete a Point (2=point)” on page 19) to use for the manual release function.
2. Select the MANREL DELAY Type Code.

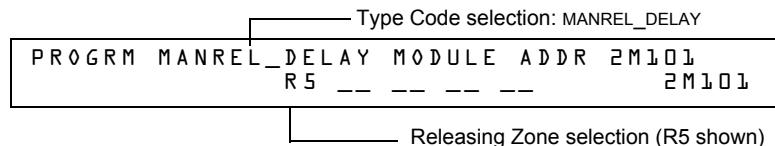

3. Select the Releasing Zone (R0-R9) for your releasing application.
4. Press the ENTER key to save, then press the ESC key until you return to the Program Change screen.

■ Examples

A programming example of a monitor module programmed for MANREL DELAY switch for Releasing Zone R5.

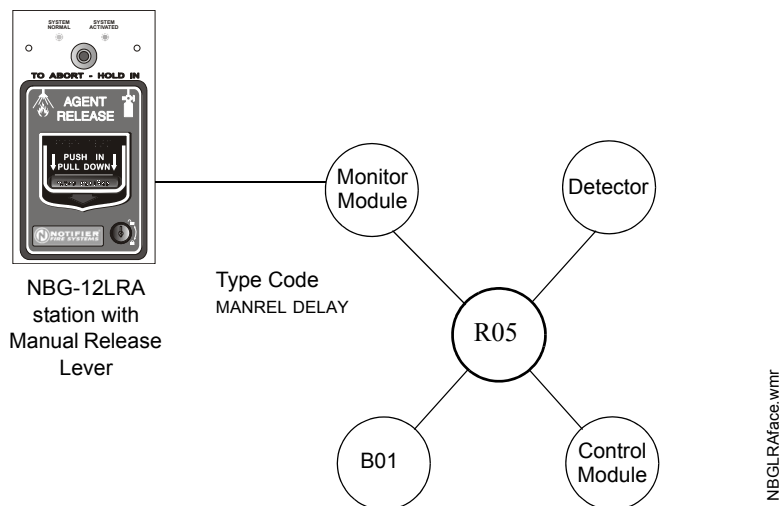

Figure A.12 Monitor Module Configured as a Manual Release Delay Switch

For examples 1, 2, and 3, program Releasing Zone R5 with a Manual Release Delay switch and the following releasing selections:

```
PRG RELEASE FUNCTION RELEASE CONTROL
DELAY=60 ABORT=ULI CROSS=N SOK=0030 R05
```

Example 1 - The FACP programmed Delay Timer begins its 60 second countdown. The Manual Release Delay switch is pulled when the FACP Delay Timer has counted down to 48 seconds (elapsed time of 12 seconds). The 48 seconds remaining in the countdown are overridden by the 30-second delay initiated by the Manual Release Delay switch. In this example, the total time elapsing from FACP countdown initiation to agent release is 42 seconds (12 + 30), less than the original 60 second FACP Delay Timer countdown.

Example 2 - The FACP programmed Delay Time begins its 60 second countdown. The Manual Release Delay switch is pulled when the FACP Delay Timer has counted down to 8 seconds. The 8 seconds remaining in the countdown is not changed when the switch is pulled. In this example, the total time elapsing from FACP countdown initiation to agent release is 60 seconds.

Example 3 - The FACP programmed Delay Time is not running (as would happen if the releasing station were pulled before an alarm registered). The Manual Release Delay Switch is activated by the pull station. Agent release will occur in 30 seconds.

For examples 4 and 5, the delay is changed to DELAY=10.

Example 4 - The FACP programmed Delay Timer begins its 10 second countdown. The Manual Release Delay switch is pulled when the FACP Delay timer has counted down to 8 seconds. The 8 seconds remaining in the countdown is not changed. In this example, the total time elapsing from FACP countdown initiation to agent release is 10 seconds.

Example 5 - The FACP programmed Delay Timer is not running (as would happen if the releasing station were pulled before an alarm registered). The Manual Release Delay switch is activated by the pull station. Agent release will occur in 10 seconds.

SECOND SHOT Type Code



NOTE: The Second Shot switch can only be used with the MANREL DELAY Type Code.

The following contains information needed to program a Second Shot switch for a monitor module

■ Description

A monitor module—connected to a UL-listed manual station (such as the NBG-12LRA)—used as for a second release of agents. A Second Shot switch overrides a Delay Timer, programmed to the same Releasing Zone.

■ Programming

1. Select a monitor module (refer to “Modify or Delete a Point (2=point)” on page 19) to use for the manual release function.
2. Select the SECOND SHOT Type Code.

```

Type Code selection: SECOND_SHOT
PROGRAM SECOND_SHOT MODULE ADDR 2M101
R 5 _ _ _ _ _ 2M101
Releasing Zone selection (R5 shown)

```

3. Select the Releasing Zone (R0-R9) for your releasing application.
4. Press the ENTER key to save, then press the ESC key until you return to the Program Change screen.

■ Examples

A programming example of a monitor module programmed as a Manual Release Delay switch (Type Code MANREL DELAY) for the first shot and a Second Shot switch (Type Code SECOND SHOT) for the second shot.

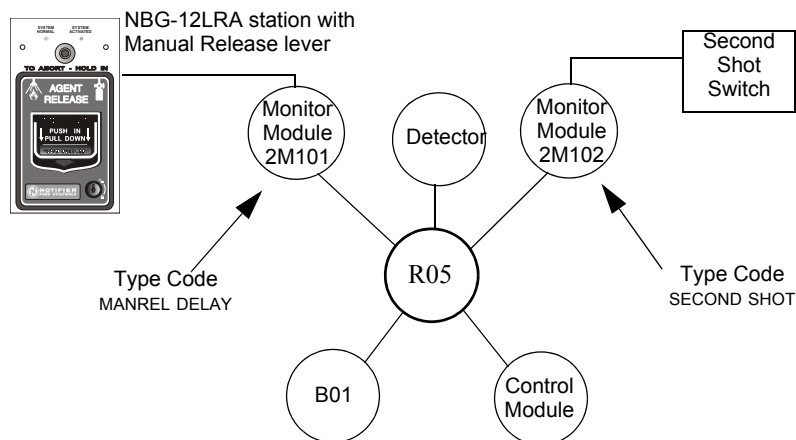

Figure A.13 Monitor Module Configured as a Second Shot Switch

With two monitor modules configured as shown above, program Releasing Zone R5 with the following releasing selections.

```

PRG RELEASE FUNCTION RELEASE CONTROL
DELAY=15 ABORT=ULI CROSS=Y SOK=0030 R05

```

R05 can be activated in one of two ways, as described in the examples given below.

Example 1: If the detector initiates the alarm, R05 activates. Releasing begins after the delay timer has expired (15 seconds). Releasing will continue for the soak timer duration (30 seconds). Once the Soak Timer expires, the Second Shot Switch can then be activated to initiate an additional soak cycle.

Example 2: If the NBG-12LRA (Type Code MANREL DELAY) lever is pulled, the delay timer begins its 15 second countdown. Releasing will begin after the delay timer has expired, and will continue for the soak timer duration (30 seconds). Once the Soak Timer expires, the Second Shot Switch can then be activated to initiate an additional soak cycle.

RELEASE END BELL



NOTE: A releasing circuit with this Type Code requires the following selections: A Releasing Zone selection (R0-R9); An output circuit mapped to the same Releasing Zone; Switch Inhibit selected; Non-Silenceable; No Walk Test.

The following contains information needed to program a Release End Bell circuit for a control module or a NAC.

■ **Description**

A control module or NAC to activate an audible or visual device when releasing devices shut off. You can also program multiple outputs with the REL END BELL Type Code to the same Releasing Zone. When all the Releasing Zone functions are complete, all outputs with the REL END BELL Type Code activate at the same time. A REL END BELL circuit remains on until you reset the system

■ **Programming**

1. Select a control module or NAC (refer to “Modify or Delete a Point (2=point)” on page 19) to use as a Release End Bell circuit.
2. Select the REL END BELL Type Code, as shown in the following example (control module shown).

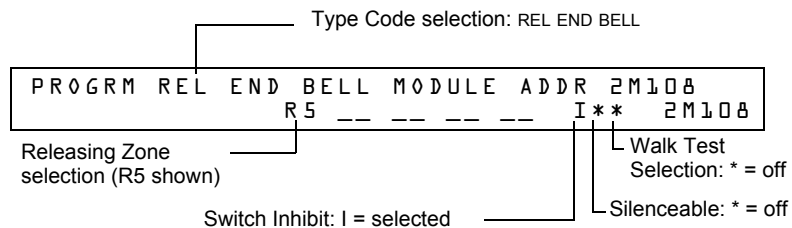

3. Select the Releasing Zone (R0-R9) for your releasing application.
4. Press the enter key to save, then press the esc key two times to return to the Program Change screen.

■ **Example**

A programming example of a control module programmed as a Release End Bell for Releasing Zone R5.

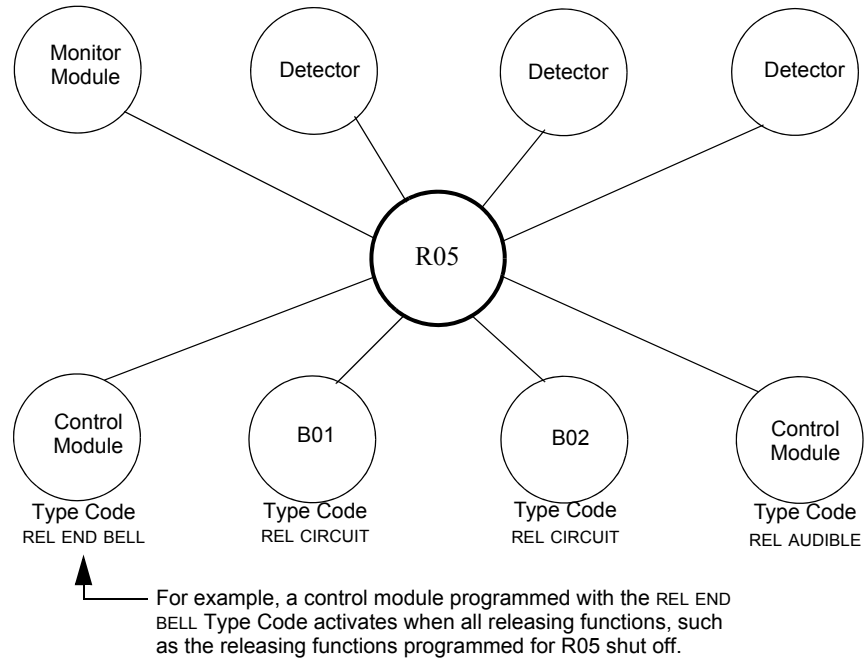

Figure A.14 Control Module Configured as a Release End Bell Circuit

REL CKT ULC Type Code



NOTE: A ULC Release Circuit with this Type Code requires the following selections: A Releasing Zone selection (R0-R9); An output circuit mapped to the same Releasing Zone; Switch Inhibit selected; Non-Silenceable; No Walk Test.

The following contains information needed to program a ULC Release Circuit for a control module or a NAC.

■ Description

A control module or a NAC used to activate a releasing solenoid or other releasing device. You can also program multiple outputs with the REL CKT ULC Type Code to the same Releasing Zone. When the Releasing Zone activates, all outputs with the REL CKT ULC Type Code also activate at the same time. A ULC Release Circuit activates when:

- An initiating device programmed to the same Releasing Zone activates (two devices if using the Cross Zone option)
- The Delay Timer for R0-R9 (if used) expires
- No Abort Switch for R0-R9 (if used) is active

A ULC Release Circuit—and all wiring to the release device—is fully supervised and usable with power-limited energy cable.

■ Programming

1. Select a control module or a NAC (refer to “Modify or Delete a Point (2=point)” on page 19) to use as a ULC Release Circuit.
2. Select the REL CKT ULC Type Code, as shown in the following example (control module shown).

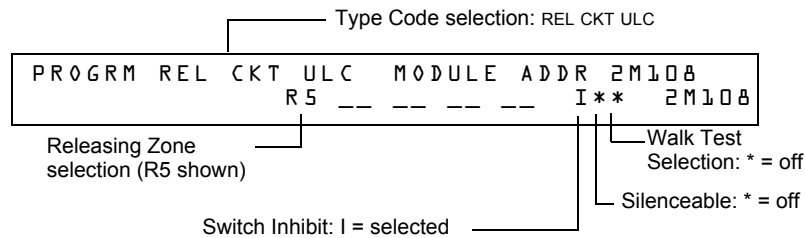

3. Select the Releasing Zone (R0-R9) for your releasing application.
4. Press the ENTER key to save, then press the ESC key two times to return to the Program Change screen.

■ **Example**

A programming example of a control module programmed as a ULC Release Circuit for Releasing Zone R5.

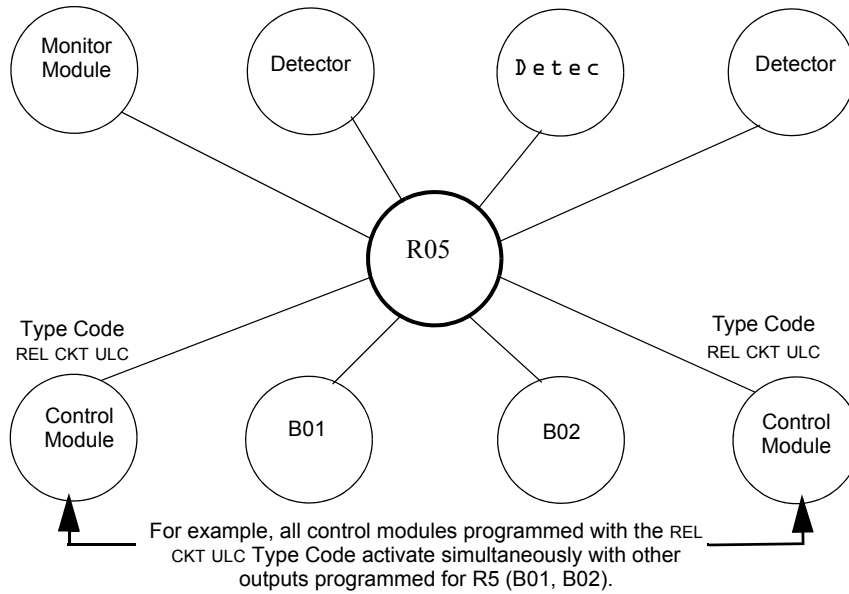

Figure A.15 Control Module Configured as a ULC Release Circuit

RELEASE CKT Type Code



NOTE: A Release Circuit with this Type Code requires the following selections: A Releasing Zone selection (R0-R9); An output circuit mapped to the same Releasing Zone; Switch Inhibit selected; Non-Silenceable; No Walk Test.



NOTE: Do not use a Release Circuit for the following: An application requiring ULC Listing; An application requiring power-limited energy cable.

The following contains information needed to program a Release Circuit for an output circuit (control module or NAC).

■ Description

A control module or a NAC used to activate a releasing solenoid or other releasing device. You can also program multiple outputs with the RELEASE CKT Type Code to the same Releasing Zone. When the Releasing Zone activates, all outputs associated with the releasing zone and with the RELEASE CKT Type Code also activate at the same time. A Release Circuit activates when:

- An initiating device programmed to the same Releasing Zone activates (two devices if using the Cross Zone option)
- The Delay Timer for R0-R9 (if used) expires
- The Abort Switch for R0-R9 (if used) is not active

■ Programming

1. Select a control module or a NAC (refer to “Modify or Delete a Point (2=point)” on page 19) to use as a Release Circuit.
2. Select the RELEASE CKT Type Code, as shown in the following example (control module shown).

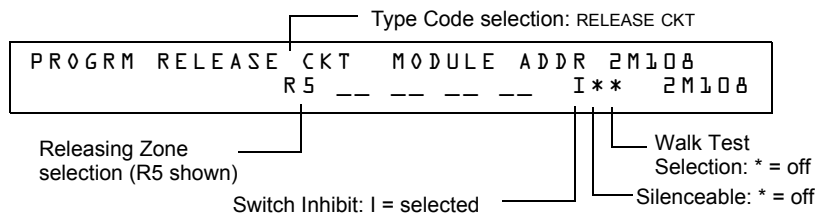

3. Select the Releasing Zone (R0-R9) for your releasing application.
4. Press the ENTER key to save, then press the ESC key two times to return to the Program Change screen.

■ **Example**

A programming example of a control module programmed as a Release Circuit for Releasing Zone R5.

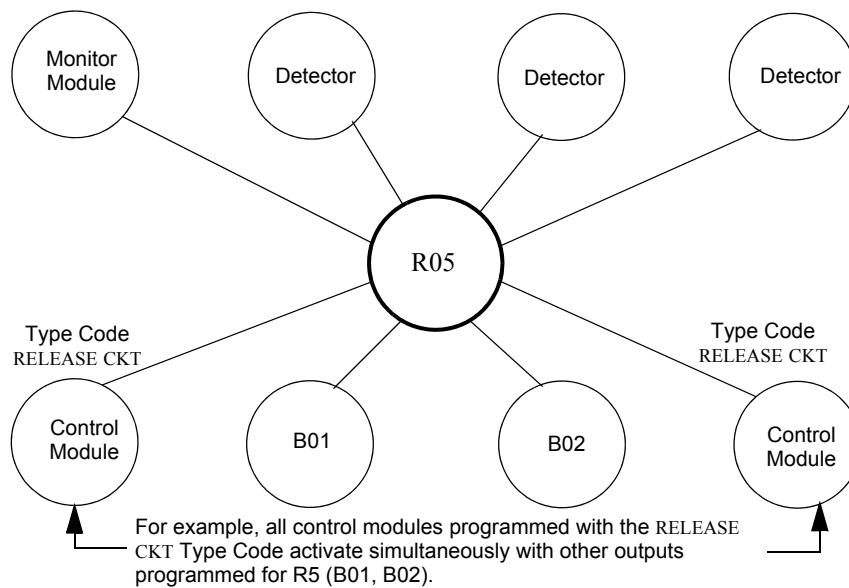

Figure A.16 Control Module Configured as a Release Circuit

Relea. Form-C Type Code



NOTE: An output with a relea.form c Type Code requires the following selections: A Releasing Zone selection (R0-R9); An output circuit mapped to the same Releasing Zone; Switch Inhibit selected; Non-Silenceable; No Walk Test.

The following contains information needed to program a Release Form-C circuit for an output circuit.

■ Description

An output circuit, configured as a relay, programmed to activate an output by opening or closing a switch. Typical applications include closing doors and air handlers.

■ Programming

1. Select a control module (refer to “Modify or Delete a Point (2=point)” on page 19) to use as a Releasing Form-C Circuit.
2. Select the RELEA.FORM C Type Code, as shown in the following example (control module shown).

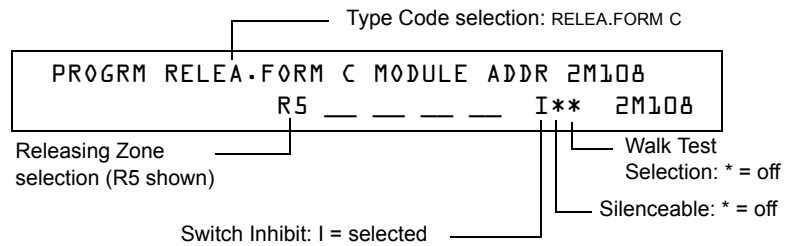

3. Select the Releasing Zone (R0-R9) for your releasing application.
4. Press the ENTER key to save, then press the ESC key two times to return to the Program Change screen.

■ Example

A programming example of a control module programmed as a Release Form-C circuit for Releasing Zone R5.

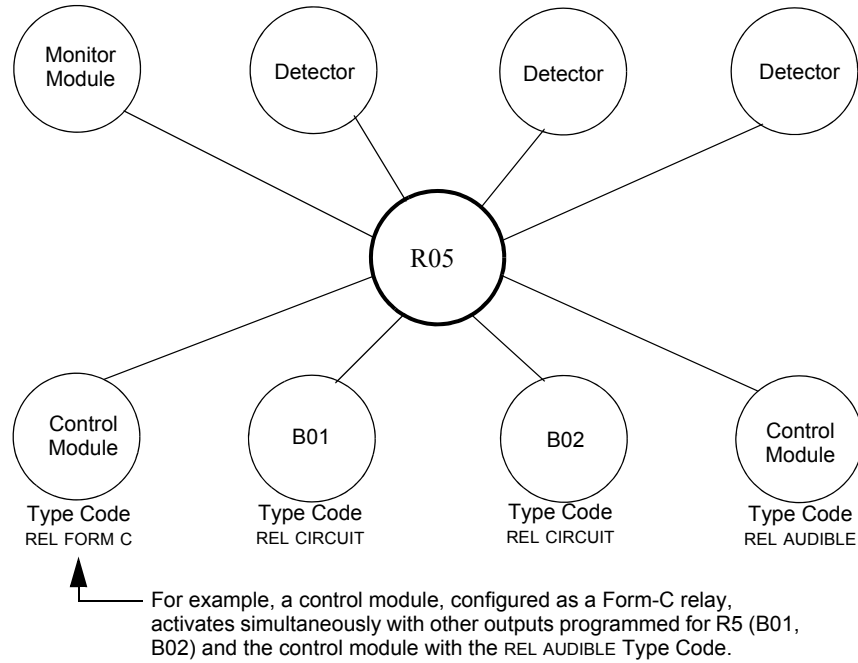

Figure A.17 Control Module Configured as a Release Form-C Circuit

REL AUDIBLE Type Code



NOTE: An output with a REL AUDIBLE Type Code requires the following selections: A Releasing Zone selection (R0-R9); An output circuit mapped to the same Releasing Zone; Switch Inhibit selected.

The following contains information needed to program a Release Audible circuit for an output circuit (control module or NAC).

■ Description

An output circuit programmed to activate an audio or visual device when all releasing outputs, programmed to the same Releasing Zone, turn on. You can also program multiple outputs with the REL AUDIBLE Type Code to the same Releasing Zone. When the Releasing Zone activates, all outputs with the REL AUDIBLE Type Code activate at the same time.

■ Programming

1. Select a control module or NAC (refer to “Modify or Delete a Point (2=point)” on page 19) to use as a Releasing Circuit.
2. Select the REL AUDIBLE Type Code, as shown in the following example (control module shown).

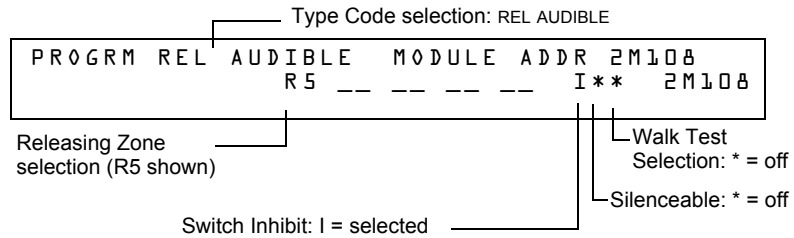

3. Select the Releasing Zone (R0-R9) for your releasing application.
4. Press the ENTER key to save, then press the ESC key two times to return to the Program Change screen.

■ **Example**

A programming example of a control module programmed as a Release Audible circuit for Releasing Zone R5.

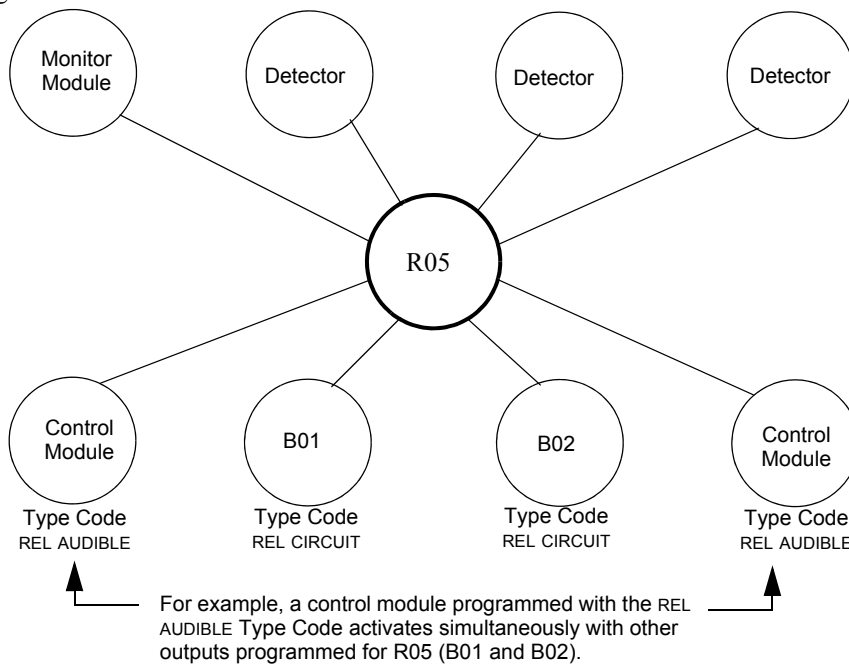

Figure A.18 Control Module Configured as a Release Audible Circuit

INSTANT RELE Type Code



NOTE: An output with an INSTANT RELE Type Code requires the following selections: a zone selection (a releasing zone may be used, but is not required); an output circuit mapped to the same zone; Switch Inhibit selected; Non-Silenceable; No Walk Test.

The following contains information needed to program an Instant Release circuit for an output circuit (control module or NAC).

■ Description

An output circuit programmed to activate non-releasing devices, such as door openers or warning sounders, without counting down delay timers. A device programmed with the INSTANT RELE Type Code device is supervised for open circuits and ground faults.

■ Programming

1. Select a control module or a NAC (refer to “Modify or Delete a Point (2=point)” on page 19) to use as a Releasing Circuit.
2. Select the INSTANT RELE Type Code, as shown in the following example (control module shown).

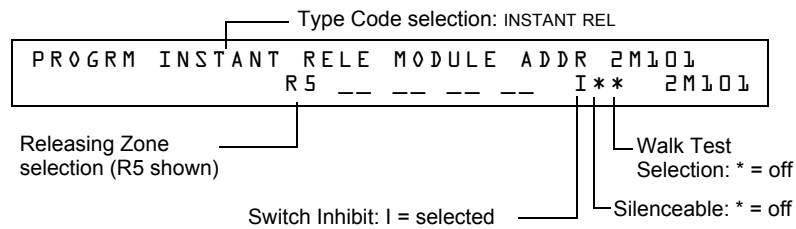

3. Select the Releasing Zone (R0-R9) for your releasing application.
4. Press the ENTER key to save, then press the ESC key two times to return to the Program Change screen.

■ Example

A programming example of a control module programmed as an Instant Release circuit for Releasing Zone R5.

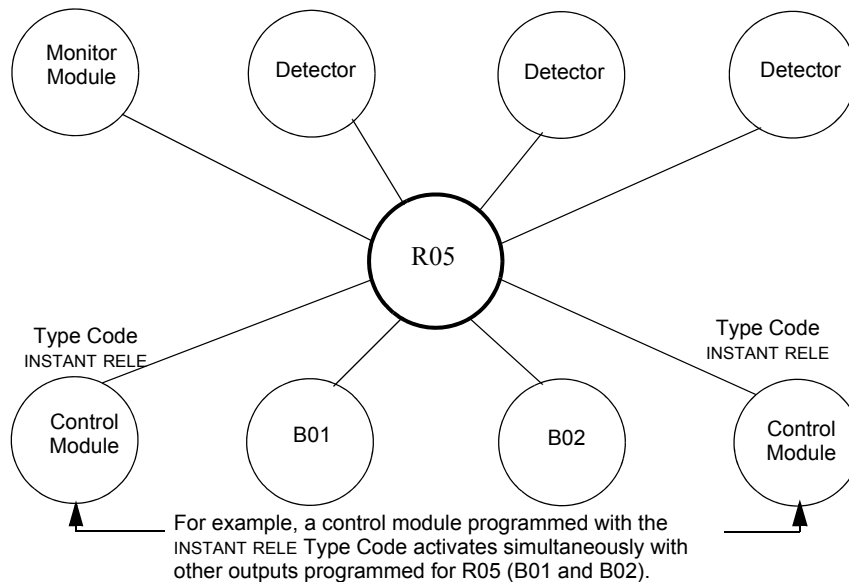

Figure A.19 Control Module Configured as an Instant Release Circuit

REL CODE BELL Type Code



NOTE: An output with a REL CODE BELL Type Code requires the following selections: A Releasing Zone selection (R0-R9); An input circuit mapped to the same Releasing Zone.



NOTE: For instructions on programming Switch Inhibit, Silenceable, and Walk Test, refer to “Modify NAC Points” on page 24.

The following contains information needed to program a Release Code Bell circuit for a NAC.

■ Description

A NAC programmed to pulse an audio or visual device as follows:

- 20 ppm when a the initial zone of a cross-zone activates.
- 120 ppm when a Cross Zone is satisfied.
- Steady when a release occurs.

■ Programming

1. Select a NAC (refer to “Modify NAC Points” on page 24) to use as a Release Code Bell Circuit.
2. Select the REL CODE BELL Type Code, as shown in the following example (NAC shown).

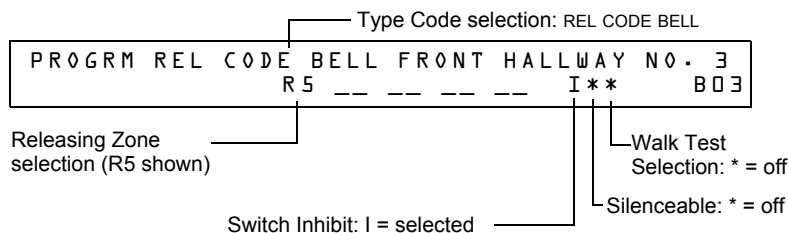

3. Select the Releasing Zone (R0-R9) for your releasing application.
4. Press the ENTER key to save, then press the ESC key two times to return to the Program Change screen.

■ Example

A programming example of a NAC programmed as a Release Code Bell circuit for Releasing Zone R5.

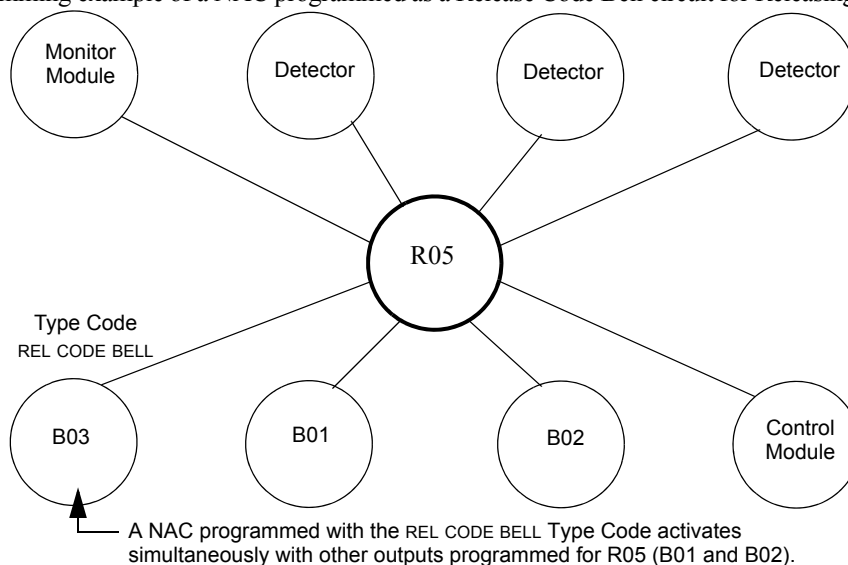

Figure A.20 NAC Configured as a Release Code Bell Circuit

A.3 Initiating Devices

Releasing zone initiating devices include the following:

- FST-851 intelligent heat detectors
- FSI-851, FSP-851, FAPT-851, FSL-751 intelligent smoke detectors
- Conventional detection UL-listed devices connected to monitor modules

Refer to the SLC manual for the most up-to-date information about initiating devices.

You can use multiple initiating devices for the same releasing hazard. Do so by mapping initiating devices to the same Releasing Zone. Factory Mutual and certain Local Authorities Having Jurisdiction require using redundant wiring (NFPA 72 Style 6 or Style D) for initiating devices in releasing applications.

A.4 Warning Sounders

Warning sounders connect to any of the four panel NACs, or to control module circuits (refer to the *NF2S-640 Installation Manual*). Note the following:

- If selecting Cross Zones, a warning sounder only activates when two zones alarm.
- Warning sounders—unlike release solenoids—do not wait for a Delay Timer.
- If Coding Functions are required for warning sounders, use one of the NACs—not a control module.
- The same releasing hazard can activate multiple NACs.

Instructions for activating warning sounders:

To activate a sounder	Do this
When the Delay Timer starts, when the releasing device activates, or both	Map the control module or NAC to a releasing hazard zone (R0-R9).
Immediately when one of the initiating devices activate	Map the control module or NAC to a separate zone (not R0-R9) that is also mapped to all initiating devices of the hazard.

A.5 Auxiliary Control Functions

Instructions for using control functions:

Function	Do this
A releasing application requires control relays	Use control modules set for dry contact operation. Program the control relays for different functions by following the instructions in “To activate a sounder” above.
Providing control functions	Use an ACM-8R remote relay module mapped to the software zones of the control panel.

A.6 ACS Annunciation

Instructions for annunciating ACS points and detectors:

To Annunciate	Do this
Points of releasing functions	Select ACS Selection Group B to annunciate any of the software zones described previously, including zones R0-R9. For instructions, refer to “Annunciator Options” on page 33.
Individual detectors	Select ACS Selection Group H, I, J, K or L. For instructions, refer to “Annunciator Options” on page 33.

Appendix B: Special Zone Outputs

B.1 Presignal and Positive Alarm Sequence (PAS)

B.1.1 What is Presignal and PAS?

Purpose

Presignal is a feature that initially causes alarm signals to only sound in specific areas, monitored by qualified persons. This allows delay of the alarm up to 180 seconds after the start of alarm processing. The control panel Presignal feature provides two selections:

- A **Presignal Delay Timer** (60-180 seconds) that delays activation of all outputs with a CBE that includes Special Zone F0.
- A **PAS** (Positive Alarm Sequence) selection, in addition to the **Presignal Delay Timer**, that allows a 15-second time period for acknowledging an alarm signal from a fire detection/initiating device. If the alarm is not acknowledged within 15 seconds, all local and remote outputs activate immediately and automatically.

An illustration of Presignal and PAS timing.

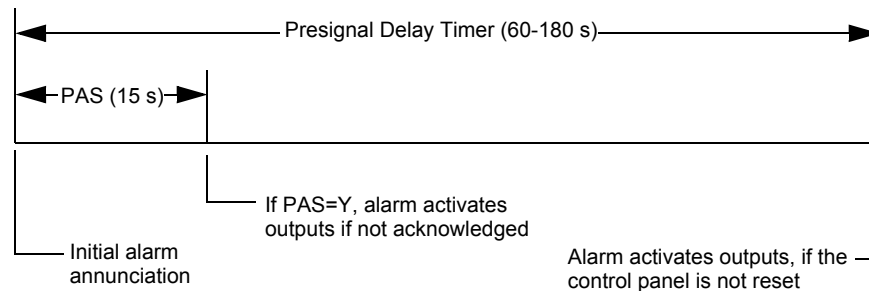

Figure B.1 Presignal and PAS Time

The control panel delays activation of outputs containing F0 in their Control-By-Event (CBE) list for all alarm initiating devices that contain F0 in their CBE list. A subsequent alarm will abort the Presignal Delay Timer and execute CBE lists.

Notes on using F0

- NFPA 72 requires installation of a PAS Inhibit switch, that can be used to turn off the PAS delay timer when the control panel is unattended. Do so by programming a monitor module with the Type Code, PAS INHIBIT. For details, refer to “Modify or Delete a Point (2=point)” on page 19.
- The Presignal Delay timer countdown can be stopped by pressing the SYSTEM RESET key before the Presignal Delay Timer expires.
- Program zone F0 to participating inputs and outputs that have appropriate CBE zone map entries.
- Outputs must be programmed for resound by fire.

Restrictions on using F0

- Do not include F0 in the CBE list for a releasing device.
- Do not include F0 in the CBE list for any monitor module that connects to a device other than an automatic fire detector.

B.1.2 Selecting Presignal and PAS Outputs

Presignal

You can set Presignal Delay Timer between 60 and 180 seconds. A Presignal Delay Timer does not apply to the following:

- The System Alarm relay
- TM-4 polarity reversal alarm output
- TM-4 municipal box output
- UDACT/UDACT-2

Positive Alarm Sequence (PAS)

Outputs selected for PAS delay for 15 seconds. Pressing the ACKNOWLEDGE/SCROLL DISPLAY key within the 15-second delay will set the Presignal Delay Timer to the full programmed value (60-180 seconds, including the PAS delay of 15 seconds). When an alarm comes from an initiating device with a CBE list that includes F0, the control panel delays the following outputs:

- System Alarm relay
- TM-4 Polarity Reversal Alarm output
- TM-4 Municipal Box output
- UDACT/UDACT-2

B.2 Time Control Zones



NOTE: All active Time Control outputs will turn off temporarily while resetting or programming the control panel

All outputs with a CBE list containing F5 or F6 activate within the times specified for the days of the week listed in F5 or F6. All smoke detectors with a CBE list containing F5 or F6 switch to their occupied level (lowest sensitivity, AL:9) within the times specified for the days of the week listed in ZF5 or ZF6. Refer to “Intelligent Sensing Applications” on page 95 for details on setting detector sensitivity.

Time Control is active for all days of the week listed in F5 or F6. Holidays listed in F7 are excluded unless you list Holidays (H) in the day-of-week selection of F5 and F6. Enter the time in a 24-hour format with the OFF time later than the ON time. After changing programming using Time Control, always reset the control panel.

B.3 Coding Functions for NACS

Coding Functions are pulsed signals that can be selected, using Special Zone F8, to energize NACs when a fire alarm activates. NACs must be programmed with a CBE list that includes F8.



NOTE: Do not include F8 in the CBE list of NACs used for releasing or zone coding applications.

Select Coding Functions on a global basis, through Special Zone F8. That is, all NACs selected for Coding Functions will sound the same code when activated. Table B.1 contains descriptions of each Coding Function selection.

Table B.1 Coding Function Selections

Coding Function Selection	Signal
March Time (default)	120 PPM (pulses per minute)
Temporal	0.5s on, 0.5s off, 0.5s on, 0.5s off, 0.5s on, 1.5s off, repeats
California	10 sec. on, 5 sec. off, repeats
Two-stage	Alert signal - 20 PPM; General Alarm Signal - Temporal
Two-Stage Canada 3	Alert Signal - 20 PPM; Drill Switch activated, 3 minute timer has expired, or device's CBE Zone activation (Z00 plus Zones 1-99 or Logic Zones 1-20) - Temporal (3 min. timeout)
Two-Stage Canada 5	Alert Signal - 20 PPM; Drill Switch activated, 5 minute timer has expired, or device's CBE Zone activation (Z00 plus Zones 1-99 or Logic Zones 1-20) - Temporal (5 min. timeout)
Two-Stage Canada Manual	Alert Signal - 20 PPM; Drill Switch activated or device's CBE Zone activation (Z00 plus Zones 1-99 or Logic Zones 1-20) - Temporal
System Sensor Strobe	Synchronizes System Sensor Horn/Strobes (Applies to NAC on CPU2-640 only) Note: If the "Strobe" Type ID is used with System Sensor Strobe synchronization, "*" will silence the horn portion only, and resound will occur only by fire alarm. F, U, B, T, or O will silence the entire circuit. Refer to "Modify an Addressable Control Module Point" on page 23 and "Modify NAC Points" on page 24
Gentex Strobe	Synchronizes Gentex Horn/Strobes (Applies to NAC on CPU2-640 only) Note: If the "Strobe" Type ID is used with Gentex Strobe synchronization, "*" will silence the horn portion only, and resound will occur only by fire alarm. F, U, B, T, or O will silence the entire circuit. Refer to "Modify an Addressable Control Module Point" on page 23 and "Modify NAC Points" on page 24
Wheelock Strobe	Synchronizes Wheelock Horn/Strobes (Applies to NAC on CPU2-640 only) Note: If the "Strobe" Type ID is used with Wheelock Strobe synchronization, "*" will silence the horn portion only, and resound will occur only by fire alarm. F, U, B, T, or O will silence the entire circuit. Refer to "Modify an Addressable Control Module Point" on page 23 and "Modify NAC Points" on page 24

Before selecting an output for Two-stage coding, note the following:

The control panel automatically sends an Alert Signal to any of the four NACs mapped to Z00 and F8, but not mapped to the alarm signal. After five minutes without an acknowledge or silence, the Alert Signal changes to Temporal pattern.

Two-stage Canada 3 and 5: Function the same as Two-stage except the second stage is achieved when

- The three or five minute timer expires without an acknowledge or silence.

OR

- The Drill Switch (or an input programmed with the type code DRILL SWITCH or EVACUATE SW) is activated.

OR

- A CBE event has occurred on the device containing both General Alarm Z00 and a general zone (Zones 1-Z99) or logic zone (Logic Zones 1-20).

If Acknowledge or Silence is pressed within the three or five minute timeout period, the NAC will remain at first stage. Subsequent alarm(s) will restart the timer.

Two-stage Canada Manual: Functions the same as Two-stage except the first stage will continue to sound until a CBE event for that device or a Drill is activated. Subsequent alarms will not activate the second stage. If a panel Reset or Silence occurs before a Drill or CBE event occurs, the second stage will not sound.

Appendix C: Intelligent Sensing Applications

C.1 Overview

“Intelligent Sensing” is a set of software algorithms that provide the *NF2S-640* with industry-leading smoke detection capability. You can program Intelligent Sensing functions on a global or on a per-detector basis.

Intelligent Sensing topics covered in this appendix:

Topic	Page
Intelligent Sensing Applications features – Descriptions of features, such as Drift Compensation, Sensitivity Adjust, programmable on a per-detector basis.	page 95
Pre-Alarm – Alert and Action settings, programming (global settings).	page 100
Detector Sensitivity Settings – Pre-Alarm and Alarm sensitivity settings for photo, ion, laser, and multisensor detectors programmable on a per-detector basis.	page 101
Detector Maintenance Features – Instructions for viewing and printing detector maintenance information.	page 103

C.2 Features

Intelligent Sensing Applications features include the following:

- Drift Compensation and Smoothing
- Maintenance Warnings - Three Levels
- Self-optimizing Pre-Alarm
- Detector Sensitivity
- Cooperative Multi-Detector Sensing

C.2.1 Drift Compensation and Smoothing

Drift compensation uses algorithms (U.S. patent pending) that identify and compensate for long-term changes in the analog readings from each smoke detector. (Typically, dirt and dust accumulation inside the smoke chamber causes long-term changes in detector readings.) Drift compensation does the following:

- Allows a detector to retain its original ability to detect actual smoke, and resist false alarms, even as dirt and dust accumulates.
- Reduces maintenance requirements by allowing the control panel to automatically perform the periodic sensitivity measurements required by NFPA Standard.

The software also provides smoothing filters to remove transient noise signals, usually caused by electrical interference. Different smoothing algorithms are used, depending on the sensitivity selection of each detector. Refer to “Detector Sensitivity Settings” on page 101 for more information on detector sensitivity levels.

A graphic representation of a detector analog reading using drift compensation and smoothing:

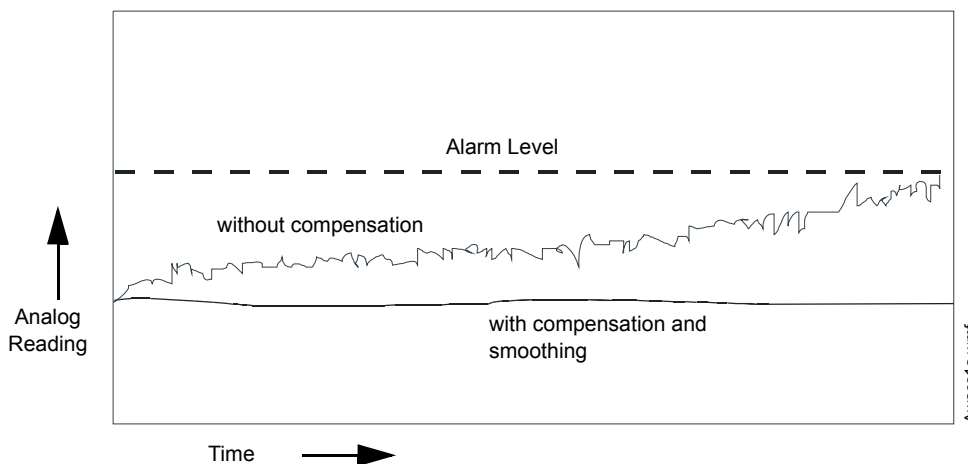

Figure C.1 Graphic Representation of Drift Compensation

C.2.2 Maintenance Warnings – Three Levels

The software determines when the drift compensation for a detector reaches an unacceptable level that can compromise detector performance. When a detector reaches an unacceptable level, the control panel indicates a maintenance warning. The table below summarizes the three levels of maintenance warnings:

Table C.1 Definitions of Maintenance Levels

Maintenance Level	Indicates
Low Chamber value	A hardware problem in the detector.
Maintenance Alert	Dust accumulation that is near but below the allowed limit. The Maintenance Alert level indicates the need for maintenance before the performance of the detector is compromised.
Maintenance Urgent	Dust accumulation above the allowed limit.

A graphic representation of the maintenance levels:

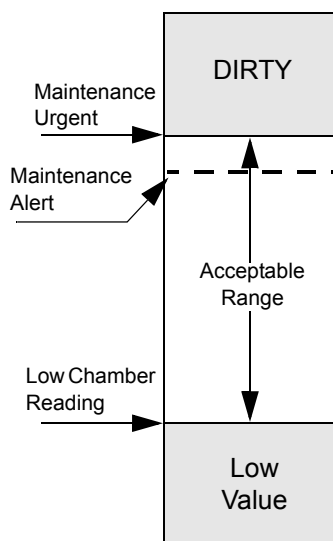

Figure C.2 Diagram of Maintenance Levels

C.2.3 Self-Optimizing Pre-Alarm

You can set each detector, except Heat, for Self-Optimizing Pre-Alarm (PA=1). In this Self-Optimizing mode, the software measures the normal peak analog readings and sets the Pre-Alarm level just above these normal peaks. This allows extremely sensitive Pre-Alarm capability with reasonable protection against non-fire signals. The figure below shows a graphical representation of the Self-Optimizing Pre-Alarm level:

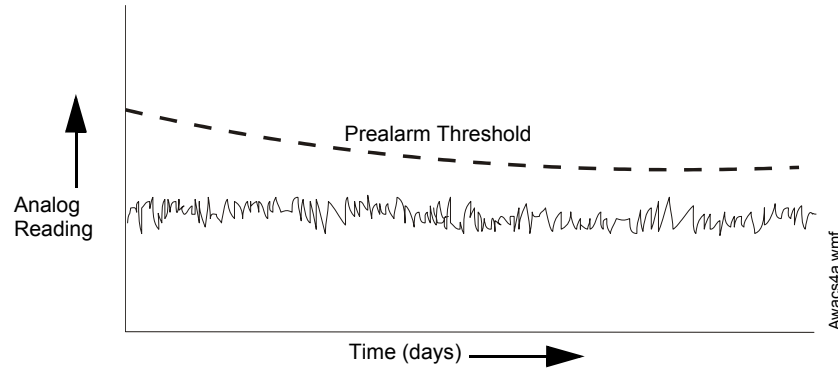

Figure C.3 Self-optimizing Pre-Alarm Level

For more information on setting Pre-Alarm levels, refer to “Changing Detector Sensitivity” on page 54

C.2.4 Detector Sensitivity

The control panel provides nine Sensitivity Levels for alarm detection and pre-alarm as follows:



NOTE: For a list of all detector sensitivity levels, see Table C.2 on page 101.

- **Alarm Sensitivity Levels** - Select the sensitivity of a detector from 1-9 (1=highest sensitivity; 9=lowest sensitivity).
- **Pre-Alarm Sensitivity Levels** - Select one of nine levels from 1 to 9 (0=no Pre-Alarm, 1=self-optimizing, 2=highest sensitivity, 9=lowest sensitivity). You can set Pre-Alarm operation to Action (latching) or Alert (non-latching) and to activate Special Zones. For instructions on programming, refer to “How to Select a Pre-Alarm Level” on page 100.

Set the sensitivity levels as fixed or programmed for day and night operation. For details, refer to “Time Control Zones” on page 93.

A sample sensitivity window for a laser detector:

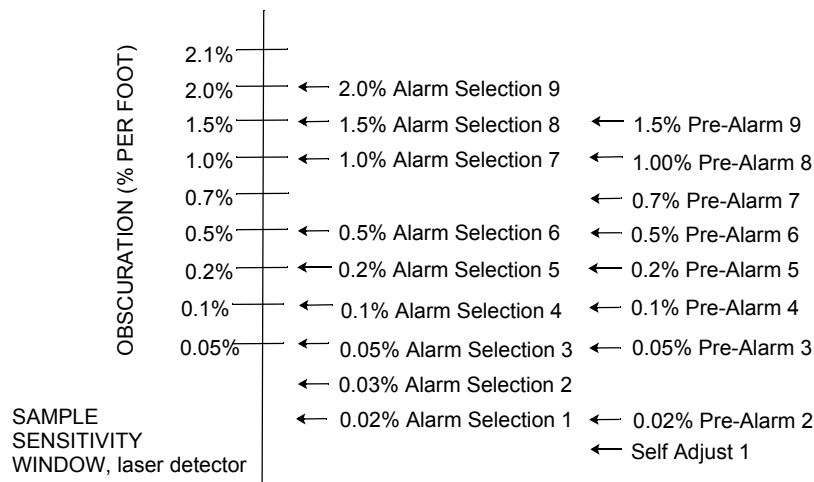

Figure C.4 Sensitivity Levels for a FlashScan View® Laser Detector

C.2.5 Cooperative Multi-Detector Sensing

Cooperative Multi-Detector Sensing is the ability of a smoke detector to consider readings from nearby detectors in making alarm or pre-alarm decisions. Each detector can include up to two other detectors in its decision. Without statistical sacrifice in the ability to resist false alarms, Cooperative Multi-Detector Sensing allows a detector to increase its sensitivity to actual smoke by a factor of almost 2 to 1. Cooperative Multi-Detector Sensing also allows the combination of ionization with photoelectric technology in reaching an alarm decision. The figure below shows a graph representing Cooperative Multi-Detector Sensing:

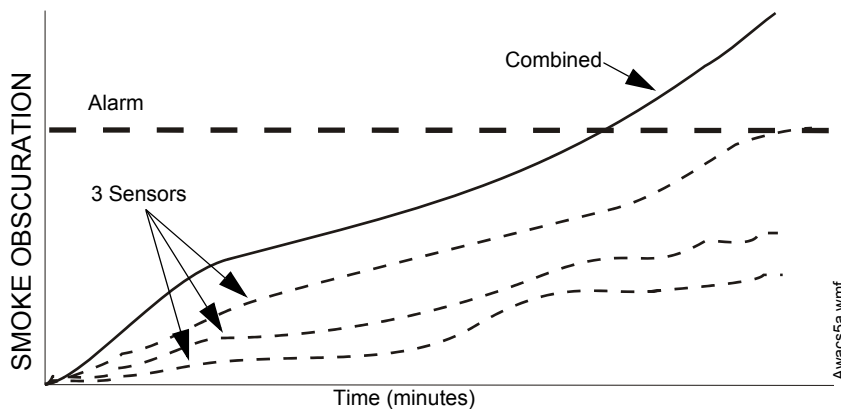

Figure C.5 Cooperative Multi-Detector Sensing

C.3 Pre-Alarm

C.3.1 Definition

The Pre-Alarm function is a programmable option which determines the system's response to real-time detector sensing values above the programmed setting. Use the Pre-Alarm function if you want to get an early warning of incipient or potential fire conditions. There are two levels of Pre-Alarm:

- Alert (Refer to “Alert Level” below)
- Action (Refer to “Action Level” on page 100)

Alert and Action Pre-Alarm settings are global. For instance, if you program Pre-Alarm for Alert, all intelligent detectors programmed for Pre-Alarm are set to Alert (refer to “How to Select a Pre-Alarm Level” on page 100). You can, however, set unique Pre-Alarm sensitivity levels (PA) for individual detectors (refer to “Detector Sensitivity Settings” on page 101).

C.3.2 Alert Level

Alert Functions

The control panel software, in addition to checking for alarm levels, checks for Pre-Alarm thresholds for each addressable, intelligent smoke detector programmed for Pre-Alarm. If a detector's real-time sensing level exceeds the programmed Alert threshold, the control panel indicates an Pre-Alarm condition for the detector. The control panel does the following functions when a detector reaches pre-alarm level:

- The Pre-Alarm message is sent to the History buffer and to any installed FDU-80s and printers. The message is sent (and time stamped) at the time that it first occurred. This historical data could provide valuable information about the progress of a fire.
- The PRE-ALARM LED flashes and the panel sounder pulses until acknowledged.
- Zone F9 activates—but Zone 00 (general alarm) or any other zone, System Trouble relay and System Alarm relay do not activate.
- The Pre-Alarm indication for this detector will restore automatically to normal if its sensitivity, programmable to one of nine settings, drops below pre-alarm level. Zone F09 clears automatically when no Pre-Alarm conditions exist.
- A subsequent alarm for this detector also clears the Pre-Alarm indication.

Example of an Alert Level

When an ion detector is programmed for AL:7 and PA:5 (covered in “Changing Detector Sensitivity” on page 54), an Alert Pre-Alarm occurs at measured smoke detector levels that exceed 1.00% per foot obscuration. When this happens the panel sounder and the PRE-ALARM LED pulse, and a display appears on the LCD, similar to the sample screen shown below:

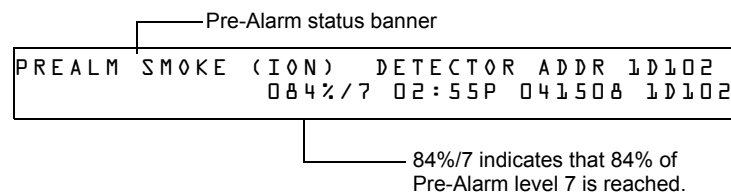

Figure C.6 Sample Display of a Pre-Alarm Alert Condition

C.3.3 Action Level

Action Functions

If you program a detector for Action Pre-Alarm and the detector reaches a level that exceeds the programmed Pre-Alarm level, the control panel indicates an Action condition. Indication at the panel is the same as in Figure C.6 above. The control panel does the following functions when a detector reaches the programmed pre-alarm level:

- The Action message is sent to the History buffer and to any installed FDU-80s and printers. The message is sent (and time stamped) only at the time that it first occurred. This historical data could provide valuable information about the progress of a fire.
- The PRE-ALARM LED and panel sounder pulse until acknowledged.
- Zone F09 is activated—but Zone Z00 (general alarm or any other zone) and the System Trouble and System Alarm relays do not activate.
- The fifth zone programmed (not the first four) for this detector activates. The fifth zone is the right-most entry on line two of the detector CBE list in the Point Programming screen. (For more information, refer to “Modify an Addressable Detector Point” on page 20). You can use the fifth zone to control functions of a detector or group of detectors once the pre-alarm level is reached. Fifth zone activations also allow ACS annunciation by a detector or group of detectors in Action Pre-Alarm condition.
- The Pre-Alarm condition and the zone programmed will latch until system reset, even if the sensitivity drops below the pre-alarm level.
- A subsequent alarm condition for this detector clears the Action indication from the LCD display alarm list.

C.3.4 How to Select a Pre-Alarm Level

Instructions and sample displays to program Pre-Alarm for Alert or Action

1. At the “Enter Password” screen, enter your Program Change Password to display the “Program Change Selection” screen. Press **1** to enter the “Basic Program” screen:

```
0 = CLR  1 = AUTO  2 = POINT  3 = PASSWD  4 = MESSAGE
5 = ZONES  6 = SPL FUNCT  7 = SYSTEM  8 = CHECK PRG
```

6 = SPL FUNCT

2. From the “Basic Program” screen, press the **6** key to display the “Special Function Zone Change” screen.

```
SPECIAL FUNCTION: F0 = PRESIG  R0 - R9 = REL
F5 - F6 = TIME  F7 = HOL  F8 = CODE  F9 = PRE-ALARM
```

F9 = PRE-ALARM

3. From the “Special Function Zone Change” screen, press **F9** to display the “Pre-Alarm Function” screen, with Alert blinking.

```
PRG  PRELARM  FUNCT  ALERT
                                F09
```

ALERT blinking

4. To select Action, press the **+** (Next Selection) or **-** (Previous Selection) key.

```
PRG  PRELARM  FUNCT  ACTION
                                F09
```

ACTION blinking

C.4 Detector Sensitivity Settings

C.4.1 How to Select Pre-Alarm and Alarm Sensitivity

Each detector provides a host of selectable intelligent options. The control panel provides nine levels of Pre-Alarm (PA:1–PA:9) and Alarm (AL:1–AL:9) in percent per foot obscuration:

- **PA:0** no Pre-Alarm selection.
- **PA:1** usually the self-optimizing setting where the control panel selects a suitable Pre-Alarm level for a detector.
- **PA:2–PA:9** the detector Pre-Alarm sensitivity level - with PA:2 the most sensitive and PA:9 the least sensitive.
- **AL:1–AL:9** the detector Alarm sensitivity level - with AL:1 the most sensitive and AL:9 the least sensitive.



NOTE: (d) Signifies the factory default setting in Table C.2.

Table C.2 Detector Sensitivity (in percent obscuration per foot) (1 of 2)

Detector Type	Alarm (FlashScan)	Alarm (CLIP)	Pre-Alarm
Photo Electric SMOKE (PHOTO) (See note *)	AL:1=0.50 % AL:2=0.73 % AL:3=0.96 % AL:4=1.19 % AL:5=1.43 % AL:6=1.66 % AL:7=1.89 % AL:8=2.12 % (d) AL:9=2.35 %	AL:1=0.50 % AL:2=0.73 % AL:3=0.96 % AL:4=1.19 % AL:5=1.43 % AL:6=1.66 % AL:7=1.89 % AL:8=2.12 % (d) AL:9=2.35 %	PA:1=Auto PA:2=0.30 % PA:3=0.47 % PA:4=0.64 % PA:5=0.81 % PA:6=0.99 % PA:7=1.16 % PA:8=1.33 % (d) PA:9=1.50 %
Ion SMOKE (ION) (See notes * and †)	AL:1=0.50 % AL:2=0.75 % AL:3=1.00 % AL:4=1.25 % AL:5=1.50 % AL:6=1.75 % (d) AL:7=2.00 % AL:8=2.25 % AL:9=2.50 %	AL:1=0.50 % AL:2=0.75 % AL:3=1.00 % AL:4=1.25 % AL:5=1.50 % AL:6=1.75 % (d) AL:7=2.00 % AL:8=2.25 % AL:9=2.50 %	PA:1=Auto PA:2=0.40 % PA:3=0.50 % PA:4=0.75 % PA:5=1.00 % PA:6=1.25 % (d) PA:7=1.50 % PA:8=1.75 % PA:9=2.00 %
FlashScan View [®] Laser (See Note ‡)	AL:1=0.02 % AL:2=0.03 % AL:3=0.05 % AL:4=0.10 % AL:5=0.20 % AL:6=0.50 % (d) AL:7=1.00 % AL:8=1.50 % AL:9=2.00 %	AL:1=0.02 % AL:2=0.03 % AL:3=0.05 % AL:4=0.10 % AL:5=0.20 % AL:6=0.50 % (d) AL:7=1.00 % AL:8=1.50 %** AL:9=2.00 %	PA:1=Auto PA:2=0.02 % PA:3=0.05 % PA:4=0.10 % PA:5=0.20 % PA:6=0.50 % (d) PA:7=0.70 % PA:8=1.00 % PA:9=1.50 %
Acclimate Plus [™] (See Note ††)	AL:1=0.50 % AL:2=1.00 % AL:3=1.00 to 2.00 % AL:4=2.00 % AL:5=2.00 to 3.00 % (d) AL:6=3.00 % AL:7=3.00 to 4.00 % AL:8=4.00 % AL:9=thermal 135°F	Alarm (CLIP) AL:1=1.00 % AL:2=1.00 % AL:3=1.00 to 2.00 % AL:4=2.00 % AL:5=2.00 to 4.00 % (d) AL:6=2.00 to 4.00 % AL:7=2.00 to 4.00 % AL:8=4.00 % AL:9=4.00 %	PA:1=0.50 % PA:2=1.00 % PA:3=1.00 % PA:4=1.00 to 2.00 % PA:5=1.00 to 2.00 % (d) PA:6=2.00 % PA:7=2.00 % PA:8=2.00 to 3.00 % PA:9=2.00 to 3.00 %
Beam Detector (See Note ††)	AL:1=25 % AL:2=30 % AL:3=40 % AL:4=50 % AL:5=30 - 50 % AL:6=40 - 50 %	AL:1=25 % AL:2=30 % AL:3=40 % AL:4=50 % AL:5=30 - 50 % AL:6=40 - 50 %	N/A

Table C.2 Detector Sensitivity (in percent obscuration per foot) (2 of 2)

Detector Type	Alarm (FlashScan)	Alarm (CLIP)	Pre-Alarm
FSC-851 IntelliQuad Detector***	AL:1=1% AL:2=2% AL:3=3% AL:4=3% w/ 10 minute confirmation††† AL:5=4% w/ 10 minute confirmation AL:6=Thermal 135°F AL:7=Thermal 135°F AL:8=Thermal 135°F AL:9=Thermal 135°F		PA:1=1% PA:2=1% PA:3=2% PA:4=3% PA:5=3% w/ 10 minute confirmation PA:6=4% w/ 10 minute confirmation PA:7=4% w/ 10 minute confirmation PA:8=4% w/ 10 minute confirmation PA:9=4% w/ 10 minute confirmation
Photo/CO	AL:1=1% AL:2=2% AL:3=3% AL:4=3% w/ 10 minute confirmation AL:5=4% w/ 10 minute confirmation AL:6=Thermal 135°F		PA:1=1% PA:2=2% PA:3=3% PA:4=3% w/ 10 minute confirmation PA:5=4% w/ 10 minute confirmation PA:6=Thermal 135°

* Detectors are suitable for open area protection within the listed air velocity range. Typically, this range is 0 - 4,000 ft/min for photoelectric detectors and 0 - 1,200 ft/min for ionization detectors. Be sure to confirm this range before installing the detector by referring to the manufacturer's installation instructions.

† Use only alarm sensitivity setting of AL=1, AL=2 or AL=3 for ION detectors installed in Canada.

‡ The use of alarm sensitivities below 0.50% obscuration per foot requires a 90 day test to ensure that the environment for the detectors is suitable for the higher sensitivity setting. (Refer to "How to Test Detectors Set Below 0.50% Obscuration per Foot" on page 102.)

** 1% maximum on CLIP. Higher figures may display.

†† For Acclimate detectors installed in Canada: Use only the alarm settings of AL:1 or AL:2.

‡‡ Refer to the beam detector manual to determine the alarm settings: they are a function of the distance between the detector and its reflector.

*** In CLIP mode, any AL: settings over AL:5 will be set to AL:5 by the panel. Any PA: settings over PA:5 will be set to PA:5 by the panel.

††† Within the 10 minute fire signature confirmation delay period if there is a detection of another fire signature (Carbon Monoxide, Infrared or Thermal) it overrides the 10 minute confirmation time.

C.4.2 How to Test Detectors Set Below 0.50% Obscuration per Foot

Using alarm sensitivities below 0.50% obscuration per foot requires a 90-day test to ensure that the detector environment is suitable for the higher sensitivity setting. To meet Notifier and Underwriters Laboratory requirements, test each detector planned to operate below 0.50%/ft obscuration as follows:

1. Set the detector as follows:

Step	Action
1	Initially set to the 0.50% obscuration per foot Alarm level.
2	Set the Pre-Alarm level to the desired final Alarm sensitivity.
3	Set the Pre-Alarm to Alert mode (non-latching).

2. Operate detectors continuously for 90 days with all environmental factors (such as, temperature, humidity, air flow, occupancy, and so on) similar to the intended application for the detectors. Record all events for each tested detector with an electronic History buffer or a printout.
3. At the end of the 90-day test: An authorized Notifier representative, or an end user trained by an authorized Notifier representative must inspect the results of the test. If the test results show no alarms or pre-alarms for the tested detectors, reprogram the fire alarm system to set the Alarm sensitivity to the more sensitive Pre-Alarm level of the test.

C.5 Detector Maintenance Features

C.5.1 Overview

The NF2S-640 provides features to check the maintenance performance level of addressable, intelligent detectors. Detector maintenance features include the following:

- View detector maintenance information for an individual detector
- Print a detector maintenance report for all detectors

C.5.2 How to Access Detector Maintenance Information

1. Access detector maintenance functions by pressing the ENTER key. The control panel displays the Program Entry screen:

```

┌=PROGRAMMING           2=READ STATUS ENTRY
(ESCAPE TO ABORT)
    
```

2. At the Program Entry screen, press the M key. The control panel displays the Detector Maintenance Selection screen:

```

SLC loop _____ Three digit address
Select Detector Address (LDAAA) <ENTER>
or Press P, <ENTER> for print all.
    
```

3. Press 1 or 2 to specify the SLC loop, then the detector’s three digit address, then press the enter key; or to print a Detector Maintenance Report (Figure C.8 on page 104): Press P; then, press the enter key.

C.5.3 View Detector Maintenance for a Detector

When you enter the detector SLC address the control panel displays the Detector Maintenance Status screen as shown below:

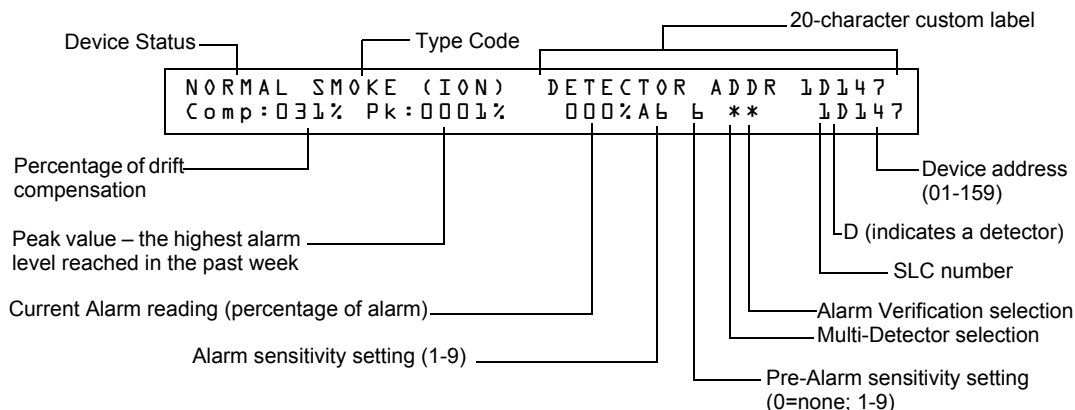

Figure C.7 Detector Maintenance Status Screen

Once you display information for a detector, you can use the **+** (Next Selection) and **-** (Previous Selection) keys to view information for the next or previous detector on the SLC.

Refer to “Interpreting a Detector Status Display or Maintenance Report” on page 104 for descriptions of each item.

C.5.4 Print a Detector Maintenance Report

A Detector Maintenance Report lists detector maintenance status for each installed addressable detector [except FDX-551(an analog heat detector)].

When you press and enter the **P** key the control panel sends a Detector Maintenance Report (Figure C.8) to the printer connected to the control panel.

```

Detector Maintenance Report
↓
*** PRINT SMOKE DETECTOR MAINTENANCE ***
NORMAL SMOKE (PHOTO) INTENSIVE CARE UNIT Comp:032% Pk:0002% 000% AB B ** 1D043
NORMAL SMOKE (PHOTO) DETECTOR ADDR 1D044 Comp:027% Pk:0001% 000% AB B ** 1D044
NORMAL SMOKE (PHOTO) DETECTOR ADDR 1D045 Comp:028% Pk:0001% 000% AB B ** 1D045
NORMAL SMOKE (PHOTO) DETECTOR ADDR 1D046 Comp:030% Pk:0001% 000% AB B ** 1D046
NORMAL SMOKE (PHOTO) DETECTOR ADDR 1D047 Comp:024% Pk:0002% 000% AB B ** 1D047
NORMAL SMOKE (PHOTO) DETECTOR ADDR 1D048 Comp:031% Pk:0002% 000% AB B ** 1D048
NORMAL SMOKE (PHOTO) DETECTOR ADDR 1D049 Comp:033% Pk:0002% 000% AB B ** 1D049
NORMAL SMOKE (PHOTO) DETECTOR ADDR 1D050 Comp:008% Pk:0003% 000% AB B ** 1D050
***** PRINT END *****

```

Figure C.8 Sample Detector Maintenance Report

C.5.5 Interpreting a Detector Status Display or Maintenance Report

Detector Maintenance Status Screens and Detector Maintenance Reports provide the same information (such as Device Status, Compensation, Peak Value) about a detector. This section contains descriptions of each item that appears in a Detector Maintenance Status Screen or a Detector Maintenance Report.

```

NORMAL SMOKE (PHOTO) DETECTOR ADDR 1D044 Comp:027% Pk:0001% 000% AB B C * 1D044
1          2          3          4          5          6          7          8          9          10         11

```

- Device Status (NORMAL)** The status of the detector: NORMAL, ALARM, DISABL OR TEST.
- Type Code (SMOKE (PHOTO))** The software Type Code that identifies the type of detector. Refer to “Intelligent Detector Type Codes” on page 112.
- Custom Label (DETECTOR ADDR 1D044)** The 19-character user-defined custom label.
- Drift Compensation (COMP:027%)** The relative cleanliness of a detector determined by sampling the amount of contaminants in the detector, ambient air conditions, and the age of the detector. The Comp value also indicates if a detector requires maintenance. Refer to “Maintenance Warnings – Three Levels” on page 96 for definitions of maintenance levels. The table below contains a list of the maintenance level values for each type of detector:

Table C.3 Maintenance Levels by Detector Type

Type of Detector	Normal	Low Chamber Reading	Maint. Alert	Maint. Urgent
Ion	006-068	less than 006	92-99	100
Photo	006-069	less than 006	93-99	100
Laser	003-063	less than 003	83-99	100
Acclimate Plus™	n/a	LO-VAL	Dirty1	Dirty2

- Peak Value (PK:0001%)** The highest analog value reached by the detector during the past week. The peak value slowly returns to zero.

6. **Alarm Reading** (000%) The current alarm reading of the detector, as a percentage of the Alarm Sensitivity setting.
7. **Alarm Sensitivity Setting** (A8) The Alarm Sensitivity (x=1-9) entered in the Detector Sensitivity Screen.
8. **Pre-Alarm Sensitivity Setting** (8) The Pre-Alarm Sensitivity (1-9; 0 = Pre-Alarm not used) entered in the Detector Settings Screen. Refer to “Detector Sensitivity Settings” on page 101 for more information on the Pre-Alarm sensitivity settings.
9. **Multi-Detector Selection** (*) A smoke detector programmed so that it evaluates readings from nearby detectors in making Alarm or Pre-Alarm decisions. Cooperative Multi-Detector sensing also allows the combination of ionization with photoelectric technology in reaching an alarm decision. See “Modify an Addressable Detector Point” on page 20 for instructions on setting Cooperative Multi-Detector Settings.
 - * – Multi-not used.
 - A** – combines the detector’s alarm decision with the next address above.
 - B** – combines the detector’s alarm decision with the next address below.
 - C** – combines the detector’s alarm decision with the next address above and the next address below.
10. **Alarm Verification** (*)
 - * – Alarm Verification not programmed for this detector.
 - V**– Alarm Verification enabled.
 - xx** – Alarm Verification programmed for the detector; xx equals the Verification Counter (00-99). See “Modify an Addressable Detector Point” on page 20 for instructions on setting Alarm Verification.
11. **Device SLC Address** (1D044) The SLC address of the detector.

Appendix D: CBE (Control-By-Event)

D.1 Description

CBE (Control-By-Event) is a software function that provides a means to program a variety of output responses based on various initiating events. The control panel operates Control-By-Event (CBE) through 99 Software Zones with the following features:

- Each input point (detector, monitor module) can list up to five Software Zones
- Each output point (control module or NAC) can list up to five Software Zones
- Output points can list zone Z00 (general alarm). Non-Alarm or Supervisory points do not activate Software Zone Z00 (general alarm)

D.2 Input and Outputs

Input and output devices with CBE-listed Software Zones work as follows:

These devices	Operate with CBE as follows
Inputs (detectors, monitor modules)	When an input device activates, so do all Software Zones listed to the input device.
Outputs (control modules and NACs)	When a Software Zone activates, the output device(s) in that zone turns on.

D.3 Equations

Space for up to twenty logic or time delay equations is included in the control panel. Each equation can be a logic equation or a time delay function. A time delay function can have a logic equation as an internal equation, but not vice versa. The rules of the equations are:

1. Equations can be entered, edited and viewed in the VeriFire™ Tools program, but can only be viewed on the control panel.
2. The twenty equations are designated in the panel as ZE0-ZE9 and ZL0-ZL9, and are evaluated in that order.



NOTE: In the VeriFire™ Tools program, ZL1 - ZL10 corresponds to ZE0-ZE9, and ZL11 - ZL20 corresponds to ZL0-ZL9.

3. Equations will always begin with a logic or a time delay function.
4. Equations will be a maximum of 73 characters long, including parentheses and commas.
5. Equations can have a maximum of 10 logic functions. The function set is listed below in “Equation Entry” on page 107.
6. These equations are to be evaluated after all other devices have been evaluated.
7. One logic equation can be used as a variable in another equation only if the equation used has previously been evaluated. For example, the results of the ZE0 equation can be used in the ZL5 equation but the opposite is not true.
8. Time delay equations can use any other functions as an internal equation, but the other function can not use time delay equation as an internal equation.
9. A logic instruction can have a maximum of 20 arguments (inclusive start and stop address).
10. Maximum for the delay timer is 18 hours 12 minutes.

D.4 Equation Entry

The equations must be entered using the VeriFire™ Tools Program Utility. All are subject to the maximum number of arguments possible in a logic instruction as discussed above (Item Number 9 on page 106).

D.4.1 Logic Functions

The “AND” Operator

Requires that each argument be in alarm.

Example: AND(Z02,Z05,Z09)

All three arguments in the equation must be in alarm for the output point to be activated.

The “OR” Operator

Requires that any argument be in alarm

Example: OR(Z02,Z05,Z09)

If any one of the three arguments in the equation is in alarm the output point will be activated.

The “NOT” Operator

Inverts the state of the argument (activated to deactivated OR deactivated to activated).

Example: NOT(Z02)

The output point will remain activated until the argument goes into alarm.

If the argument goes into alarm the output point will deactivate.

The “ONLY1” Operator

Requires that only one argument be in alarm.

Example: ONLY1(Z02,Z05,Z09)

If only one of the arguments is in alarm the output point will be activated.

The “ANY2” Operator

Requires that two or more arguments be in alarm.

Example: ANY2(Z02,Z05,Z09)

If any two or more of the arguments are in alarm the output point will be activated.

The “ANY3” Operator

Requires that three or more arguments be in alarm.

Example: ANY3(Z02,Z05,Z07,Z09)

If any three or more of the arguments are in alarm the output point will be activated.

The “XZONE” Operator

Requires that any combination of two or more input devices programmed to a zone be in alarm.

Example: XZONE(Z02)

If any combination of two or more initiating devices that have been programmed (CBE) to this software zone comes into alarm, then this output point will be activated.

The “RANGE” Operator

Each argument within the range must conform to the requirements of the governing operator. The range limit is 20 consecutive arguments.

Example: AND(RANGE(Z1,Z20))

Zone 1 through Zone 20 must all be in alarm for the output point to be activated.

D.4.2 Equation Syntax Example

OR(AND(L1D1,L1D4),AND(L2D6,L2M3,NOT(L2M4)),ANY2(L1M13,L1M14,L1M15))

Equation begins with a logic or time delay function - OR

67 Characters (maximum of 73) - includes parentheses and commas.

5 Logic Functions (maximum of 10) - OR, AND, AND, NOT and ANY2.

8 Arguments (maximum of 20 per logic function) - L1D1,L1D4,L2D6,L2M3,L2M4....

The equation contains no spaces.

D.4.3 Evaluating an Equation

When you evaluate an equation, you start from the innermost part of the equation and work outwards. For this equation to evaluate TRUE and thus turn on any output mapped to it, the following conditions must be met:

OR(AND(L1D1,L1D4),AND(L2D6,L2M3,NOT(L2M4)),ANY2(L1M13,L1M14,L1M15))

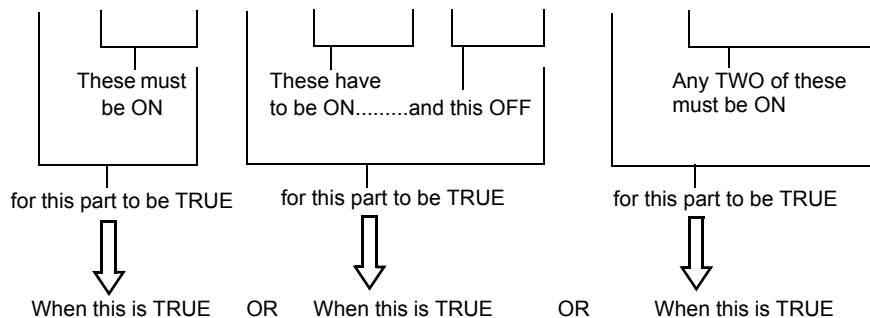

Then all outputs programmed with this equation will be turned ON.

D.4.4 Argument Entries

The argument entries of the logic functions can be another logic function or any of the devices listed below:

1D1 – 1D159	detectors loop 1	(159)
1M1 – 1M159	modules loop 1	(159)
2D1 – 2D159	detectors loop 2	(159)
2M1 – 2M159	modules loop 2	(159)
B1 – B4	panel bells	(4)
Z0 – Z99	zones	(100)
F0 – F9	special function zones	(10)
R0 – R9	releasing zones	(10)
ZE0 – ZE9**	equations 0-9	(10)
ZL0 – ZL9***	equations 10-19	(10)
*Node numbers can be entered in VeriFire™ Tools for network programming.		
**Corresponds in VeriFire™ Tools to ZL1-ZL10		
***Corresponds in VeriFire™ Tools to ZL11-ZL20		

Equations must be evaluated before use in another equation.

D.4.5 Time Delay Functions

The “DEL” Operator

Used for delayed operation

Example: DEL(HH:MM:SS,HH:MM:SS,ZE5)

- The first HH:MM:SS is the delay time, the second HH:MM:SS is the duration time.
- If delay of zero is entered (00.00.00), the equation will evaluate true as soon as the internal equation (ZE5) evaluates true and will remain that way for the specified duration, unless the internal equation becomes false.
- If no duration is specified, then the device will not be deactivated until a reset occurs or the internal equation evaluates false.

The “SDEL” Operator

A latched version of the DEL operator. Once the equation evaluates true, it remains activated until a reset, even if the internal equation (ZE5) becomes false.

Example: SDEL(HH:MM:SS,HH:MM:SS,ZE5)

- The first HH:MM:SS is the delay time, the second HH:MM:SS is the duration time.
- If delay of zero is entered (00.00.00), the equation will evaluate true as soon as the internal equation (ZE5) evaluates true and will remain that way for the specified duration.
- If no duration is specified, then the device will not deactivate until reset.

The installer can enter the equations in any combination wanted as long as the format of the logic function or time delay is followed from the lists above. Error checking will be performed after the user has entered the complete equation. Possible errors are too many or too few parentheses, too many or too few arguments inside the parentheses, unknown function and unknown device type.

D.5 CBE Example

An example of CBE, where monitor module 1M101 lists zone Z04 and Z05, and control module 1M108 lists zone Z05 and zone Z07:

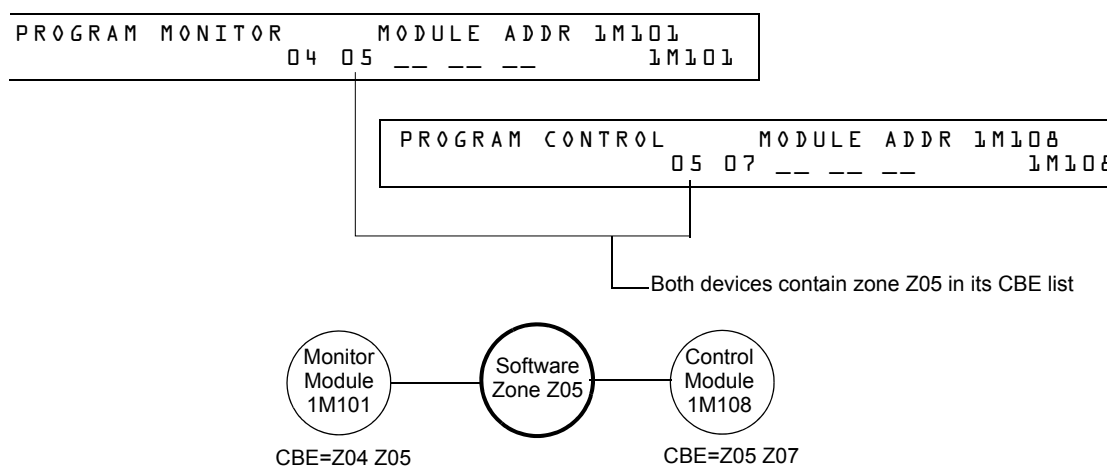

Figure D.1 CBE Example

When monitor module 1M101 activates, the following CBE takes place:

1. Software Zones Z04 and Z05 activate.
2. Since control module 1M108 has Z05 in its CBE list, all of its outputs would activate. All output devices with Z04 or Z05 would activate.

Appendix E: Detector Initialization

E.1 Overview

The control panel automatically performs a detector initialization routine when you add or change a detector, unless the control panel is in Walk Test or Advanced Walk Test. If you change a detector with the control panel in Walk Test or Advanced Walk Test, you must manually initialize the detector as detailed in “How to Manually Initialize a Detector” on page 111. The detector initialization routine takes approximately 2.5 minutes, during which time the FACP remains in service. While initializing a detector, follow these guidelines:

- Make sure the detector is free of residual smoke during detector initialization.
- Do not test a detector during detector initialization.



NOTE: The control panel only performs detector initialization if it senses that a detector was removed for at least 15 seconds. This is what actually “turns on” the detector.—It is an automatic procedure but is specified here because of the delay between detector connection and full function. The rest of the system remains in full service during this time.

A sample screen that appears on the LCD display during detector initialization.

```
Detector Initializing _ Please Wait  
02:48P 041508 Sat
```



WARNING:

If you replace any detector with a different type of detector (for example, replace a laser detector with a photoelectric detector), you must immediately program the control panel with the new detector Type Code. Failure to do so can cause incorrect control panel operation, including false alarms. For instructions on replacing a detector, refer to “How to Replace a Detector” on page 110.

E.2 System Testing and Detector Initialization

To facilitate system testing, the control panel does not initialize detectors during Walk Test and Advanced Walk Test. You can remove a detector to confirm supervision, then replace the detector for immediate testing. If you replace a removed detector with a different detector of the same type, you must manually initialize the detector according to the instructions in “How to Manually Initialize a Detector” on page 111. If, however, you want to replace a removed detector with a different type of detector, refer to “How to Replace a Detector” on page 110.

E.3 How to Replace a Detector

If you replace a detector with a different type of detector, you must immediately program the control panel for the new detector type. To replace a detector, follow these steps:



NOTE: Parentheses show an example of replacing an existing photoelectric detector at address 1D101 with a laser detector.

Step	Action
1	Disable the point of the detector. (point 1D101)
2	Remove the photoelectric detector and replace with laser detector set to the same address.
3	Autoprogram the panel to recognize the new detector type.
4	Enable new detector.

E.4 How to Manually Initialize a Detector

You only need to manually initialize a detector when you change a detector during Walk Test or Advanced Walk Test. If, however, you replace a detector with a different type of detector, you must immediately program the new detector according to the instructions in “How to Replace a Detector” on page 110.

To manually initialize a detector, follow these steps:

1. Press the ENTER key. The control panel displays the Program Entry screen:

```
1=PROGRAMMING          2=READ STATUS ENTRY
(ESCAPE TO ABORT)
```

2. Press the 1 key. The control panel displays the Enter Password screen:

```
ENTER PROG OR STAT PASSWORD, THEN ENTER.
(ESCAPE TO ABORT)
```

3. Enter the password RESET, which starts detector initialization. The control panel displays the following three screens, in the sequence shown, while initializing a detector:

```
CHECKING MEMORY NFS2-640 Release 1.0
Software #XXXXXXX
```

```
Detector Initializing _ Please Wait
02:48P 041508 Tue
```

When the control panel completes the detector initialization, it displays system status as shown below:

```
SYSTEM NORMAL          02:50P 041508 Tue
```

Appendix F: Type Codes

F.1 What are Type Codes?

Type Codes are software selections for initiating devices (detectors and monitor modules) and output devices (control modules and NACs). Some Type Codes are self-explanatory; that is, the Type Code matches the function of the device, such as a “Monitor” for a monitor module, “Photo” for a photoelectric detector, and so on. Type codes also provide special functions, such as activating switches, solenoids, and control panel functions.

F.2 How to Select a Type Code

You select a Type Code through the Point Programming screen. For instructions, refer to “Modify an Addressable Detector Point” on page 20.

F.3 In this Appendix

This appendix contains detailed descriptions of Type Codes for input and output devices, as listed below:

Type of Device	Refer to page
F.4.2, "Type Codes for Intelligent Detectors"	page 112
F.4.3, "Type Codes for Monitor Modules"	page 114
F.5.2, "Type Codes for Control Modules"	page 115
F.5.3, "NAC Type Codes"	page 116

F.4 Type Codes for Input Devices

F.4.1 Overview

This section provides Type Codes for intelligent detectors and monitor modules. For instructions on programming Type Codes, refer to “Modify or Delete a Point (2=point)” on page 19.

F.4.2 Type Codes for Intelligent Detectors

A list of intelligent detector Type Codes, which specify the type of detector installed at an SLC address.

Table F.1 Intelligent Detector Type Codes (1 of 3)

Type Code	Point Characteristics			Device Function
	Point Type	Latching (Y/N)	Point Function	
SMOKE (ION)	fire alarm	Y	lights fire alarm LED and activates CBE	Ionization smoke detector
SMOKE(DUCTI)	fire alarm	Y	lights fire alarm LED and activates CBE	Duct Ionization smoke detector
SUP.T(DUCTI) ³	supervisory	N	lights supervisory LED	Ionization smoke detector used as a duct detector to report supervisory condition rather than alarm. Tracking.
SUP.L(DUCTI)	supervisory	Y	lights supervisory LED	Ionization smoke detector used as a duct detector to report supervisory condition rather than alarm. Latching.
SUP.T(ION) ^{2,3}	supervisory	N	lights supervisory LED	Ionization smoke detector used to report supervisory condition rather than alarm. Tracking.
SUP.L(ION) ²	supervisory	Y	lights supervisory LED	Ionization smoke detector used to report supervisory condition rather than alarm. Latching.
SMOKE(PHOTO)	fire alarm	Y	lights fire alarm LED and activates CBE	Photoelectric smoke detector
SMOKE(DUCTP)	fire alarm	Y	lights fire alarm LED and activates CBE	Duct Photoelectric smoke detector
SUP.T(DUCTP) ³	supervisory	N	lights supervisory LED	Photoelectric smoke detector used as a duct detector to report supervisory condition rather than alarm. Tracking.

Table F.1 Intelligent Detector Type Codes (2 of 3)

SUP.L(DUCTP)	supervisory	Y	lights supervisory LED	Photoelectric smoke detector used as a duct detector to report supervisory condition rather than alarm. Latching.
SUP.T(PHOTO) ^{2,3}	supervisory	N	lights supervisory LED	Photoelectric smoke detector used to report supervisory condition rather than alarm. Tracking.
SUP.L(PHOTO) ²	supervisory	Y	lights supervisory LED	Photoelectric smoke detector used to report supervisory condition rather than alarm. Latching.
RF_PHOTO	fire alarm	Y	lights fire alarm LED and activates CBE	Wireless Photoelectric smoke detector
SMOKE(HARSH) ¹	fire alarm	Y	lights fire alarm LED and activates CBE	HARSH smoke detector
PHOTO/CO ⁴	fire alarm	Y	lights fire alarm LED for photo and heat, no LED will light for a CO alarm, photo and heat will activate CBE, CO alarm activates special function zone FC and sixth CBE zone only (sixth CBE zone programmable via VeriFire Tools)	Photoelectric, Carbon Monoxide, and Heat detector
PHOTO/CO (P SUP) ^{2,4,5}	fire alarm/ supervisory	Y	lights fire alarm LED for heat, no LED will light for a CO alarm, supervisory LED will light for photo alarm, heat and photo will activate CBE, CO alarm activates special function zone FC and sixth CBE zone only (sixth CBE zone programmable via VeriFire Tools)	Photoelectric, Carbon Monoxide, and Heat detector
PHOTO/CO (C SUP) ⁴	fire alarm/ supervisory	Y	lights fire alarm LED for heat and photo alarms, will light supervisory LED for CO alarm, photo and heat alarms will activate CBE, CO alarm will activate sixth CBE zone only (sixth CBE zone programmable via VeriFire Tools)	Photoelectric, Carbon Monoxide, and Heat detector
SMOKE(BEAM)	fire alarm	Y	lights fire alarm LED and activates CBE	Beam smoke detector
SMOKE(LASER)	fire alarm	Y	lights fire alarm LED and activates CBE	Laser smoke detector
SUP.L(LASER) ²	supervisory	Y	lights supervisory LED	Laser smoke detector used to report supervisory condition rather than alarm. Latching.
SUP.T(LASER) ^{2,3}	supervisory	N	lights supervisory LED	Laser smoke detector used to report supervisory condition rather than alarm. Tracking.
SMOKE(DUCTL)	fire alarm	Y	lights fire alarm LED and activates CBE	Duct Laser smoke detector
SUP T(DUCTL)	supervisory	N	lights supervisory LED	Laser smoke detector used as a duct detector to report supervisory condition rather than alarm. Tracking.
SUP L(DUCTL)	supervisory	Y	lights supervisory LED	Laser smoke detector used as a duct detector to report supervisory condition rather than alarm. Latching.
AIR REF	fire alarm	Y	lights fire alarm LED and activates CBE	Assign to one or more FSL-751 detectors used to monitor the quality of air entering the protected area. The air quality measurement allows the VIEW [®] system to compensate for vehicle fumes, fog, or other particles brought into the protected area through the ventilation system. Poor air quality will lower the sensitivity of all FSL-751 detectors on the SLC. The detector sensitivity, however, remains within approved limits (always less than 1% obscuration per foot).
NOTE: A reference detector still functions as a smoke detector, but you should set the detector sensitivity level to the least sensitive level—AL:9 and PA:9 Change Alarm and Pre-Alarm sensitivity. Refer to “Detector Sensitivity Settings” on page 101 for a complete list of detector sensitivity settings.				
HEAT	fire alarm	Y	lights fire alarm LED and activates CBE	190°F intelligent thermal sensor
HEAT+	fire alarm	Y	lights fire alarm LED and activates CBE	190°F intelligent thermal sensor with low temperature warning.
HEAT(FIXED)	fire alarm	Y	lights fire alarm LED and activates CBE	135°F intelligent thermal sensor
HEAT (ROR)	fire alarm	Y	lights fire alarm LED and activates CBE	15°F per minute rate-of-rise detector
SMOKE ACCLIM	fire alarm	Y	lights fire alarm LED and activates CBE	Combination Photoelectric/heat detector without freeze warning (Acclimate Plus™)
SMOKE(ACCLI+)	fire alarm	Y	lights fire alarm LED and activates CBE	Combination Photoelectric/heat detector with freeze warning (Acclimate Plus™, or IntelliQuad FSC-851 Photoelectric Multi-Criteria Smoke Sensor)
SMOKE(MULTI) ¹	fire alarm	Y	lights fire alarm LED and activates CBE	Multisensor smoke detector
ASPIRATION	fire alarm	Y	lights fire alarm LED and activates CBE	Aspiration smoke detector
ASPIR (SUP)	supervisory	Y	lights supervisory LED and activates CBE	Aspiration detector supervision
ASPIR (PRE)	prealarm	N	lights prealarm LED and activates CBE	Aspiration detector prealarm
ASPIR (NON)	non-fire	N	activates CBE	Aspiration detector non-alarm
ASPIR (REF)	non-fire	N	activates CBE	Used as a reference for other aspiration detectors on the loop
NOTE: Aspiration detector (FAAST) programming requires 5 SLC addresses.				

Table F.1 Intelligent Detector Type Codes (3 of 3)

¹ CLIP Mode only
² Requires approval of AHJ.
³ Not suitable for Canadian applications.
⁴ LED representation of a CO alarm may be performed using an ACS annunciator.
⁵ Photo element can be programmed as latching or tracking for all Photo/Co devices programmed as this type ID via VeriFire Tools.

F.4.3 Type Codes for Monitor Modules

A list of monitor module Type Codes, which you can use to change the function of a monitor module point.

Table F.2 Type Codes for Monitor Modules (1 of 2)

Type Code	Point Type	Point Characteristics		Device Function
		Latching (Y/N)	Point Function	
MONITOR	fire alarm	Y	Lights fire alarm LED and activates CBE	Alarm-monitoring device
PULL STATION	fire alarm	Y	Lights fire alarm LED and activates CBE	Manual fire-alarm-activating device, such as a pull station
RF MON MODUL	fire alarm	Y	Lights fire alarm LED and activates CBE	Wireless alarm-monitoring device
RF PULL STA	fire alarm	Y	Lights fire alarm LED and activates CBE	Wireless manual fire-alarm-activating device, such as a pull station
SMOKE CONVEN	fire alarm	Y	Lights fire alarm LED and activates CBE	Indicates activation of a conventional smoke detector attached to an FZM-1
SMOKE DETECT	fire alarm	Y	Lights fire alarm LED and activates CBE	Indicates activation of a conventional smoke detector attached to an FZM-1
WATERFLOW	fire alarm	Y	Lights fire alarm LED and activates CBE	Monitor for waterflow alarm switch
WATERFLOW S	supervisory	Y	Lights supervisory LED and activates CBE	Indicates supervisory condition for activated waterflow switch
ACCESS MONTR	non-alarm	N	Activates CBE	Used for monitoring building access
AREA MONITOR	security	Y	Lights security LED and activates CBE	Monitors building access
AUDIO SYSTEM	trouble	N	Lights trouble LED	Used for monitoring audio equipment
EQUIP MONITR	security	N	Activates CBE	Used for recording access to monitored equipment
RF SUPERVSRV	supervisory	N	Lights Supervisory LED	Monitors a radio frequency device
SECURITY	security	Y	Lights security LED	Indicates activation of security alarm
LATCH SUPERV	supervisory	Y	Lights supervisory LED	Indicates latching supervisory condition
TRACK SUPERV	supervisory	N	Lights supervisory LED	Monitors for waterflow tamper switches for alarm points
SYS MONITOR	security	Y	Lights security LED and activates CBE	Monitors equipment security
TAMPER	supervisory	Y	Lights supervisory LED, activates CBE	Indicates activation of tamper switch
ACK SWITCH	non-alarm	N	Performs Acknowledge function, no CBE	Silences panel sounder, gives an Acknowledge message on the panel LCD
ALLCALL PAGE	non-alarm	N	Activates all speaker circuits, no CBE	Performs AMG-1 All-call
DRILL SWITCH	non-alarm	N	Performs Drill function	Activates silenceable outputs
EVACUATE SWITCH	non-alarm	N	Performs Drill function	Activates all silenceable outputs
FIRE CONTROL	non-alarm	N	Activates CBE	Used for non-fire activation of outputs
NON FIRE	non-alarm	N	Activates CBE	Used for building energy management
PAS INHIBIT	non-alarm	N	Inhibits Positive Alarm Sequence	Inhibits Positive Alarm Sequence
POWER MONITR	trouble	N	Indicates trouble	Monitors auxiliary power supplies
RESET SWITCH	non-alarm	N	Performs Reset function	Resets control panel
SIL SWITCH	non alarm	N	Performs Signal Silence function	Turns off all activated silenceable outputs
TELE PAGE	non-alarm	N	Performs function of Page Button on FFT-7	Allows remote paging to a fire area
DISABLE MON	disable	N	When a point with this type code activates, it will create a disable on the panel for that point. No CBE generated.	Module can not be disabled via ACS, Alter Status, or over the network.
TROUBLE MON	trouble	N	Indicates Trouble	Monitors trouble inputs
ABORT SWITCH	non alarm	N	Indicates Active at the panel	Aborts activation of a releasing zone
MAN RELEASE	fire alarm	Y	Lights Fire Alarm LED and activates CBE	Indicates activation of a monitor module programmed to releasing zone to perform a releasing function
MANREL DELAY	fire alarm	Y	Lights Fire Alarm LED and activates CBE	Indicates activation of a monitor module programmed for a release output
SECOND SHOT	fire alarm	Y	Indicates Active at the panel and activates CBE	Provides second activation of releasing zone after soak timer has expired.
Blank	fire alarm	Y	Lights fire alarm LED and activates CBE	Monitors for a device with no description
HEAT DETECT	fire alarm	Y	Lights fire alarm LED and activates CBE	Monitors for conventional heat detector

Table F.2 Type Codes for Monitor Modules (2 of 2)

CO MON ¹	CO alarm	Y	No LED will light. Special Function Zone FC and the sixth CBE zone will activate (sixth CBE programmable via VeriFire Tools.)	Monitors conventional CO detector
ECS/MN MONITOR ³	MN alarm	Y	Does not light any LEDs, overrides existing fire event ² , shuts off silenceable outputs and all fire activated strobes and activates CBE.	Monitors mass notification devices
ESC/MN SUPT	supervisory	N	Lights supervisory LED and activates CBE.	Monitors mass notification devices
ECS/MN SUPL ³	supervisory	Y	Lights supervisory LED and activates CBE.	Monitors mass notification devices.
ECS/MN TROUBLE MON ³	trouble	N	Indicates trouble on a Mass Notification device.	Monitors mass notification devices. Will generate a trouble condition for both open and short conditions.
RF GATEWAY	non-alarm	N	Activates CBE	Provides communication between wireless device and the fire panel.

¹ LED representation of a CO alarm may be performed using an ACS annunciator.

² If ECS/MN Override is not selected in VeriFire Tools, the fire events take precedence over ESC/MN audio events.

³ This type code is not compatible with FirstCommand applications.

F.5 Type Codes for Output Devices

F.5.1 Overview

This section provides Type Codes for control modules and NACs. For instructions on programming Type Codes, refer to “Modify or Delete a Point (2=point)” on page 19.

F.5.2 Type Codes for Control Modules

A comprehensive list of control module Type Codes, which you can select to change the function of an control module point.

Table F.3 Control Module Type Codes (1 of 2)

Type Code	Silenceable (Y/N)	Configuration	Device Function
CONTROL	Y	NAC	Supervised NAC for notification appliance
RELAY	Y	Form-C relay	Relay output
BELL CIRCUIT	Y	NAC	Supervised NAC for notification appliance
STROBE CKT	Y	NAC	Supervised NAC for notification appliance
HORN CIRCUIT	Y	NAC	Supervised NAC for notification appliance
AUDIBLE CKT	Y	NAC	Supervised NAC for notification appliance
SPEAKER	Y	NAC	Supervised NAC for notification appliance
ISOLATED NAC	Y	NAC	Supervised NAC for notification appliance, used with audio isolators. Activates even if there is a short on its NAC circuit. For ULC installations only.
ISOLATED SPK	Y	NAC	Supervised NAC for speaker circuits, used with audio isolators. Activates even if there is a short on its audio circuit. For ULC installations only.
REL END BELL	N	NAC	Supervised NAC for notification appliance
blank	Y	NAC	Supervised NAC (for use when no other Type Code applies)
REL CKT ULC*	N	NAC	Releasing Circuit, power-limited, supervised for opens, shorts and ground faults (always non-silenceable)
RELEASE CKT*	N	NAC	Releasing circuit, nonpower-limited, supervised for opens and ground faults
RELEA.FORM C*	N	Form-C Relay	Relay output, contacts operate upon release
REL AUDIBLE	Y	NAC	NAC, activated upon release
NONRESET CTL	N	Form-C Relay and NAC	Relay output, unaffected by “System Reset” command
TELEPHONE	N	NAC	Standard Telephone circuit
INSTANT RELE	N	NAC	NAC, short = normal; supervised for open circuits and ground faults. Always non-silenceable and switch-inhibited.
ALARMS PEND.	N	NAC	Output that will activate upon receipt of an alarm condition, and remain in the alarm state until all alarms have been acknowledged. It is programmed as “switch inhibit”.
CONTROL NAC	Y	NAC	Supervised NAC
GEN ALARM	N	NAC	Control Module, an XPC-8 circuit, or an XP5-C (in NAC mode) configured as a Municipal Box Transmitter for NFPA 72 Auxiliary Fire Alarm Systems applications. This Type ID can also be used for general alarm activation. It is programmed as “switch inhibit”.

Table F.3 Control Module Type Codes (2 of 2)

GEN SUPERVIS	N	NAC	Control Module, an XPR-8 relay, or an XP5-C (in relay mode) activated under any Supervisory condition (includes sprinkler type). It is programmed as "switch inhibit".
GEN TROUBLE	N	NAC	Control Module, an XPR-8 relay, or an XP5-C (in relay mode) activated under any System Trouble condition. It is programmed as "switch inhibit".
GENERAL PEND	N	NAC	Control Module, an XPC-8 circuit, or an XP5-C (in NAC mode) that will activate upon receipt of an alarm and/or trouble condition, and remain in the ON state until all events have been ACKNOWLEDGED.
TROUBLE PEND	N	NAC	Control Module, an XPC-8 circuit, or an XP5-C (in NAC mode) that will activate upon receipt of a trouble condition, and remain in the ON state until all troubles have been ACKNOWLEDGED. It is programmed as "switch inhibit".
MNS GENERAL	N	NAC	Mass notification supervised output.
MNS CONTROL ¹	N	NAC	Mass notification supervised NAC.
MNS STROBE ¹	N	NAC	Mass notification supervised NAC.
MNS SPEAKER ¹	N	NAC	Mass notification supervised NAC for speaker circuits.
MNS RELAY ¹	N	NAC	Mass notification relay output.

* The FCM-1-REL checks for shorts with all releasing type codes.

¹ The type code is not compatible with FirstCommand applications.

F.5.3 NAC Type Codes

A comprehensive list of Type Codes for panel NACs. For instructions on programming Type Codes, refer to "Modify or Delete a Point (2=point)" on page 19.

Table F.4 NAC Type Codes

Type Code	Silenceable (Y/N)	Device Function
CONTROL	Y	Supervised NAC
BELL CIRCUIT	Y	Supervised NAC for notification appliance
STROBE CKT	Y	Supervised NAC for notification appliance
HORN CIRCUIT	Y	Supervised NAC for notification appliance
AUDIBLE CKT	Y	Supervised NAC for notification appliance
SPEAKER	N	Supervised NAC for speaker circuits
REL END BELL	N	Supervised NAC
blank label	Y	Supervised NAC for undefined device
REL CKT ULC	N	Releasing Circuit, power-limited, supervised for opens, shorts and ground faults (always non-silenceable)
RELEASE CKT	N	Releasing circuit, nonpowerlimited, supervised for opens and ground faults
REL AUDIBLE	Y	NAC, activated upon release
REL CODE BELL	Y	Supervised NAC (NFS2-640 NAC only)
INSTANT RELE	N	NAC, short = normal; supervised for open circuits and ground faults. Always non-silenceable and switch-inhibited.
ALARMS PEND	N	Output that will activate upon receipt of an alarm condition, and remain in the alarm state until all alarms have been acknowledged. It is programmed as "switch inhibit".
CONTROL NAC	Y	Supervised NAC
GEN ALARM	N	Control Module, an XPC-8 circuit, or an XP5-C (in NAC mode) configured as a Municipal Box Transmitter for NFPA 72-2002 Auxiliary Fire Alarm Systems applications (MBT-1 required). This Type ID can also be used for general alarm activation. It is programmed as "switch inhibit".
GEN SUPERVIS	N	Control Module, an XPR-8 relay, or an XP5-C (in relay mode) activated under any Supervisory condition (includes sprinkler type). It is programmed as "switch inhibit".
GEN TROUBLE	N	Control Module, an XPR-8 relay, or an XP5-C (in relay mode) activated under any System Trouble condition. It is programmed as "switch inhibit".

Table F.4 NAC Type Codes

GENERAL PEND	N	Control Module, an XPC-8 circuit, or an XP5-C (in NAC mode) that will activate upon receipt of an alarm and/or trouble condition, and remain in the ON state until all events have been ACKNOWLEDGED.
TROUBLE PEND	N	Control Module, an XPC-8 circuit, or an XP5-C (in NAC mode) that will activate upon receipt of a trouble condition, and remain in the ON state until all troubles have been ACKNOWLEDGED. It is programmed as "switch inhibit".

Appendix G: Region Settings

The REGION panel programming selection provides a setting for China. (Refer to “The Utility Program” on page 48.) This selection activates the following features:

- POM-8A support
- Active output events displayed. A counter is displayed for active outputs.
- Municipal communication panel settings
- New special function zone for alarm verification
- Prealarm automatically cleared after five minutes
- Co-op detectors alarm functions
- Dual alarm window
- Points in trouble will not activate
- Ten minute limit for DEL and SDEL delay functions
- Disable events do not light LED or trip the trouble relay
- no system trouble generated upon entering program mode
- Low AC operation of FACP
- Power supply troubles

Appendix H: Intelligent Sounder Base Programming and Operation

The NFS2-640 is compatible with the B200 Intelligent Sounder Base. This sounder base allows for multiple tone generation that is user programmable via VeriFire Tools.

Programming the Intelligent Sounder Base into the Control Panel:

Once the sounder base has been installed and a detector has been plugged into the sounder base, you can do one of the following to program the sounder base into the control panel:

- Autoprogram—Perform an autoprogram at the control panel. The sounder base will have the same SLC device address as the detector installed on the sounder base. Once the Autoprogram is performed, the display will show the number of sounder bases installed on the control panel. Refer to *Section 2.3.2, “Autoprogram the Control Panel (I=auto)”*, on page 15.
- VeriFire Tools —Using VeriFire™ Tools, program the detector that is to be installed in the sounder base and select the Intelligent Sounder Base option. Refer to the *VeriFire Tools Help File* for additional information.

Intelligent Sounder Base Options:

The sounder base has user programmable options that can be modified via VeriFire Tools. These features and their defaults are as follows:

Table H.1 Intelligent Sounder Base Options

Feature:	Description and Options:	Default:
Zone Mapping	<p>The sounder base allows for up to three (3) zones to be programmed for specific tone generation. The tones available are:</p> <ul style="list-style-type: none"> • Continuous • Temp-3 • Temp-4 • March Time <p>The first of the three zones has the highest priority, the second zone has second priority, and the third has third priority.</p>	<p>No zones mapped. (When set as default, a fire alarm will generate a Temp-3 tone and a CO alarm will generate a Temp-4 tone.)</p>
Silence and Resound	<p>The intelligent sounder base may be programmed for silenceable operation as well as signal resound. The silence and resound options available are:</p> <ul style="list-style-type: none"> • No silence • Silence and resound by Fire Alarm • Silence and resound by Supervisory • Silence and resound by CO alarm • Silence and no resound 	<p>Silenceable and Resound by Fire</p>

Notes

Index

A

- Abort Switch **28, 29, 60**
 - basic configuration example **63**
 - configuration example with monitor module **74**
 - Definition **62**
 - how it works **62**
 - to program **62, 74**
 - Type Code (ULI,IRI,NYC, or AHJ) **60**
- AC delay enable **32**
- Acclimate, detector sensitivity settings **101**
- ACS Annunciation, releasing applications **91**
- ACS annunciators
 - ACS Selection Groups A through W **35–41**
 - annunciation points **34**
 - annunciator display **34**
 - Selection Groups, global setting **32**
 - selection of display information **33**
- AHJ Abort Switch
 - example **69**
 - programming **68**
- Alarm
 - Alarm Verification Timer **31**
 - Scroll **48**
 - to select sensitivity **101**
- Alarm Verification Counters. See Detector headings. **55**
- Alarm Verification Timer **31**
- annunciation points **34**
- Argument **108**
- Auto Silence Timer **31**
- Autoprogram **14, 15–18**
 - default values **18**
 - to add/remove device **16**
 - to create a new program **15**
- Auxiliary Control Functions, releasing applications **91**

B

- BACKUP option switch for NACs **60**
- Basic Program **13, 14–47**
- Baud rate
 - CRT Serial Port **51**
 - Printer Serial Port **50**
- Beam, detector sensitivity settings **101**
- Blink rate for SLC device LED **32**

C

- California Code **28, 94**
- Canadian Two-Stage **94**

Caution

- Definition **8**
- Do not program detectors as CLIP... **50**
- Do not program more than 99 CLIP... **50**
- CBE (Control-By-Event) **106–109**
 - example **109**
- CBE list **20, 92, 93**
- Check option (program errors) **47**
- Clear memory **15**
- CLIP (Classic Loop Interface Protocol) **13, 49**
- Coding Function Selections **94**
- Coding, Special Zone F8 **18, 28, 30, 93**
- Control Module
 - to program **23**
- Cooperative Multi-Detector Sensing **98**
- Cross Zone **28, 29, 60**
 - programming example **71**
 - to activate a Releasing Zone **70**
 - Types **70, 71**
- Custom label **20**

D

- DCC Mode **49**
- Default values, autoprogram **18**
- Delay Timer **28, 29, 60**
 - to program **61**
- Detector
 - Alarm Sensitivity Levels **97**
 - Initialization and System Testing **110**
 - Pre-Alarm Sensitivity Level **97**
 - Print a Detector Maintenance Report **104**
 - Program Values **20**
 - to Access Detector Maintenance Information **103**
 - to change sensitivity level **52, 54**
 - to clear alarm verification counters **52, 55**
 - to disable programmed points **52**
 - to manually initialize **111**
 - to program point **20**
 - to replace **110**
 - to Test Detectors Set Below 0.50% Obscuration per Foot **102**
- Detector Initialization **110–111**
- Device
 - to add **16**
 - to remove **17**
- Drift Compensation **95**
 - graphic representation **96**

E

- Equations
 - Argument Entries **108**

- Evaluating **108**
- logic and time delay **106**
- Logic Functions **107**
- rules **106**
- Time Delay Functions **109**

F

- FCM-1-REL, 2 second delay **18, 29**
- FireVoice **40**
- FlashScan
 - Devices, SLC options **49**
 - Poll **13, 49**
- FSC-851, detector sensitivity settings **102**

G

- Gentex Strobes **28**
- Gentex Strobes, special zone **94**
- Global System Functions **14**
 - defaults **31**
 - to change **31**

H

- History
 - Clear History **52, 55**
- Holiday **18, 30**
- Holiday, special zone **28**

I

- Initiating Devices, releasing zone **91**
- Instant Release Circuit
 - control module configuration example **89**
 - to program **89**
- Intelligent Sensing Applications **95–105**
 - Drift Compensation **95**
 - Maintenance Warnings, 3 levels **96**
 - Smoothing **95**
- Intelligent Sounder Base Programming **119**
- Ion FSI-751, detector sensitivity settings **101**
- IP ACCESS **19, 49**
- IRI Abort Switch
 - example **65**
 - to program **65**

K

- keypad **10**

L

- Labels **21**
 - note about spaces **21**
- Local Control **48**
- LocM operating mode **32**
- LocT operating mode **32**
- Logic Functions **107**

M

- Maintenance Levels by Detector Type **104**
- Maintenance Warnings **96**
- Manual Release Delay Switch
 - monitor module configuration example **77**
 - to program **76**
- Manual Release Switch
 - monitor module configuration example **75**
 - to program **75**
- Manually Initialization, detector **111**
- March Time **28, 94**
- Mass Notification **28**
- Master Box trouble message **33**
- Monitor
 - default zones **22**
 - to disable programmed points **52**
 - to program monitor **22**

N

- NAC
 - to disable programmed points **52**
- NBG-12LRA **62, 74, 75, 76, 78**
- Network node **47**
 - As argument entry **108**
- Network Program **13, 47**
 - network node number range **47**
- NFPA Standards for Releasing Applications **61**
- NFS2-640 keypad **10**
- NYC Abort Switch
 - examples **67**
 - programming **66**

O

- Operating parameters, to change. See Status Change

P

- PAS Inhibit switch **92**
- Password
 - Program Change (high level) **11**
 - Status Change (low level) **11, 52**
 - to change **25**
 - to enter **11**
- Point, to disable/enable **53**
- Poll, see FlashScan™ Poll, CLIP Poll
- Pre-Alarm **99**
 - Action Functions **100**
 - Alert Level **99**
 - to select a level **100**
 - to select sensitivity **101**
- Pre-Alarm, special zone **18, 28, 31**
- Presignal Delay Timer/PAS **18, 28, 29, 92**
- Program Change **13–51**
- Program Errors, check for **47**

R

- REGION Setting **48**
- Regional Settings **118**
- Release Audible Circuit
 - control module configuration example **88**
 - to program **87**
- Release Circuit
 - control module configuration example **84**
 - to program **83**
- Release Code Bell Circuit
 - NAC configuration example **90**
 - to program **90**
- Release End Bell Circuit
 - control module configuration example **80**
- Release End Bell Circuit, to program **79**
- Release Form-C Circuit
 - control module configuration example **86**
 - to program **85**
- Releasing Zones (R0-R9) **14, 18, 27, 29, 60**
 - type codes for inputs/outputs **73**
- RemT operating mode **32**
- Resound **23, 25, 48**

S

- Second Shot Switch **78**
 - monitor module configuration example
- Self-Optimizing Pre-Alarm **97**
- Sensitivity level for detector **52, 54**
- Silence Inhibit Timer **31**
- Smoothing **95**
- Soak Timer **28, 29, 60**
 - to program (NFPA 16 applications only) **72**
- Special Function, See Special Zones
- Special Zone Outputs **92–94**
- Special Zones
 - F0-F9 **14, 27**
 - FA, FB, FC **14, 27**
 - Special Zone F0, notes and restrictions **92**
- Special Zones F1-F4 **28**
- Status Change **52–59**
 - Options **52**
- Strobes, See System Sensor, Gentex, Wheelock
- Strobes, special zone
- Style 4 network setting **47**
- Style 4 SLC wiring, global setting **32**
- Style 6 SLC wiring, global setting **32**
- Style 7 network setting **47**
- System clock **52**
- System Message, custom **14, 19, 26**
- SYSTEM NORMAL message **18**
- System Sensor Strobes, special zone **28, 94**

T

- Temporal Code **28, 94**

- Terminal mode supervision enable **32**
- Threshold Ch.A/B **47**
- Time
 - to set time/date for system clock **52, 55**
 - USA or European **32**
- Time control, special zones **18, 28, 30, 93**
- Time Delay Functions **109**
- TM-4 **33, 93**
- Trouble reminder **48**
- Two-Stage **28, 94**
- Two-Stage Canada **28, 94**
- Two-Stage Canada Manual **28, 94**
- Type Code
 - for releasing zone inputs/outputs **73**
- Type Codes **112–116**
 - explanation **112**
 - for Control Modules **115**
 - for Intelligent Detectors **112**
 - for Monitor Modules **114**
 - for NACs **116**
 - to select **112**

U

- UDACT **33**
- UDACT-2 **33**
- ULC Release Circuit
 - control module configuration example **82**
 - to program **81**
- ULI Abort Switch
 - example **64**
 - to program **64**
- Utility Program **13, 48**

V

- VeriFire™ Tools **10, 106, 107, 119**

W

- Walk Test **52**
 - Activation Indications **58**
 - Advanced **58**
 - Basic
 - audible **57**
 - silent **57**
 - trouble **57**
- WARNING
 - Definition **8**
 - Disabling a zone disables all input and output devices.... **53**
 - Do not rely on disable/enable....to lock out releasing devices. **53**
 - If you replace any detector with a different type... **110**
 - Physically disconnect all releasing devices **56**
 - The IRI abort switch will only work if....

65

Walk Test mode can deactivate fire protection... **56**

When used for CO2 releasing applications... **60**

Warning Sounders, releasing applications **91**

Wheelock Strobes **28**

Wheelock Strobes, special zone **94**

Z

Zones

Custom label **14, 27**

Software Zones 01-99 **18**

to disable programmed points **52**

Z00 general alarm **18, 23, 47, 94, 100, 106**

Manufacturer Warranties and Limitation of Liability

Manufacturer Warranties. Subject to the limitations set forth herein, Manufacturer warrants that the Products manufactured by it in its Northford, Connecticut facility and sold by it to its authorized Distributors shall be free, under normal use and service, from defects in material and workmanship for a period of thirty six months (36) months from the date of manufacture (effective Jan. 1, 2009). The Products manufactured and sold by Manufacturer are date stamped at the time of production. Manufacturer does not warrant Products that are not manufactured by it in its Northford, Connecticut facility but assigns to its Distributor, to the extent possible, any warranty offered by the manufacturer of such product. This warranty shall be void if a Product is altered, serviced or repaired by anyone other than Manufacturer or its authorized Distributors. This warranty shall also be void if there is a failure to maintain the Products and the systems in which they operate in proper working conditions.

MANUFACTURER MAKES NO FURTHER WARRANTIES, AND DISCLAIMS ANY AND ALL OTHER WARRANTIES, EITHER EXPRESSED OR IMPLIED, WITH RESPECT TO THE PRODUCTS, TRADEMARKS, PROGRAMS AND SERVICES RENDERED BY MANUFACTURER INCLUDING WITHOUT LIMITATION, INFRINGEMENT, TITLE, MERCHANTABILITY, OR FITNESS FOR ANY PARTICULAR PURPOSE. MANUFACTURER SHALL NOT BE LIABLE FOR ANY PERSONAL INJURY OR DEATH WHICH MAY ARISE IN THE COURSE OF, OR AS A RESULT OF, PERSONAL, COMMERCIAL OR INDUSTRIAL USES OF ITS PRODUCTS.

This document constitutes the only warranty made by Manufacturer with respect to its products and replaces all previous warranties and is the only warranty made by Manufacturer. No increase or alteration, written or verbal, of the obligation of this warranty is authorized. Manufacturer does not represent that its products will prevent any loss by fire or otherwise.

Warranty Claims. Manufacturer shall replace or repair, at Manufacturer's discretion, each part returned by its authorized Distributor and acknowledged by Manufacturer to be defective, provided that such part shall have been returned to Manufacturer with all charges prepaid and the authorized Distributor has completed Manufacturer's Return Material Authorization form. The replacement part shall come from Manufacturer's stock and may be new or refurbished. THE FOREGOING IS DISTRIBUTOR'S SOLE AND EXCLUSIVE REMEDY IN THE EVENT OF A WARRANTY CLAIM.

Warn-HL-08-2009.fm



World Headquarters
12 Clintonville Road
Northford, CT 06472-1610 USA
203-484-7161
fax 203-484-7118

www.notifier.com

ISO 9001
CERTIFIED
ENGINEERING & MANUFACTURING
QUALITY SYSTEMS